

# Contemporary Art vs. The Museum

Why is acquiring and caring for contemporary art so challenging?

Presented by Sydney Briggs, Ellen Conti,  
Brandi Pomfret, with Daniel Hanford

## Henri Matisse

### *Dance (I) [La Danse (I)]*

Paris, Boulevard des Invalides, early 1909

Oil on canvas

8' 6 1/2" x 12' 9 1/2"

Gift of Nelson A. Rockefeller in honor of Alfred H. Barr, Jr.



## Pablo Picasso

### *Monument*

New York, 1972

Cor-Ten steel

12' 11 5/8" x 58 3/4" x 10' 5 3/4"

Gift of the artist





DOROTHY H. DUDLEY, 4TH FROM LEFT, GRADUATING  
FROM THE NEWARK PROGRAM IN 1925. PHOTO  
COURTESY OF NEWARK MUSEUM.



## Robert Gober

### *Untitled*, 2003-2005

Plaster, fir, wool, linen, photolithograph on acid-free paper, oil paint, semi-gloss enamel paint, watercolor, pastel, graphite, bronze, cast plastic, polyethylene, lead crystal, fiberglass, nickel plated bronze, wood, water, recycling pumps, stoneware, urethane, rubber, cement, feather re-creation of American Robin, blown glass, Flashe paint, aluminum, pewter, beeswax, human hair, pigment, socks, and shoes  
Dimensions variable

Gift of Maja Oeri and Hans Bodenmann



**Josh Kline**

*Skittles*, 2014

Commercial refrigerator, light box and blended liquids in bottles

86 1/2 × 127 1/2 × 41" (219.7 × 323.9 × 104.1 cm)

Fund for the Twenty-First Century

Photo: © Yuko Torihara, Canal 47, NY

## Rirkrit Tiravanija

*untitled 1992/1995 (free/still), 1992/1995/2007/2011-*

Refrigerator, table, chairs, wood, drywall, food and other materials

Dimensions variable

Gift of Mr. and Mrs. Eli Wallach (by exchange)





## Cai Guo-Qiang

### *Borrowing Your Enemy's Arrows*, 1998

Wood boat, canvas sail, arrows, metal, rope, Chinese flag, and electric fan

Boat approximately 60" x 23' 7" x 7' 6" (152.4 x 720 x 230 cm), each arrow approximately 24" (62 cm)

Gift of Patricia Phelps de Cisneros in honor of Glenn D. Lowry

## Nalini Malani

### *Gamepieces*, 2003/2009

Four-channel video/shadow play (color, sound; 12 min) and  
synthetic polymer paint on six Lexan cylinders

Dimensions variable

Gift of the Richard J. Massey Foundation for Arts and Sciences







**Joan Jonas**

*Mirage*, 1976/1994/2005

Six videos (black and white, sound and silent; duration variable), props, stages, and photographs

Dimensions variable

Gift of Richard J. Massey, Clarissa Alcock Bronfman, Agnes Gund, and Committee on Media Funds

## Bruce Nauman

### *Think*, 1993

Two color video monitors, two laser disc players, two laser discs (color, sound), and metal table

Dimensions variable

Gift of Werner and Elaine Dannheisser



## Bruce Nauman

### *Think*, 1993/2009

Two color video monitors, two laser disc players, two laser discs (color, sound), and metal table

Dimensions variable

Gift of Werner and Elaine Dannheisser



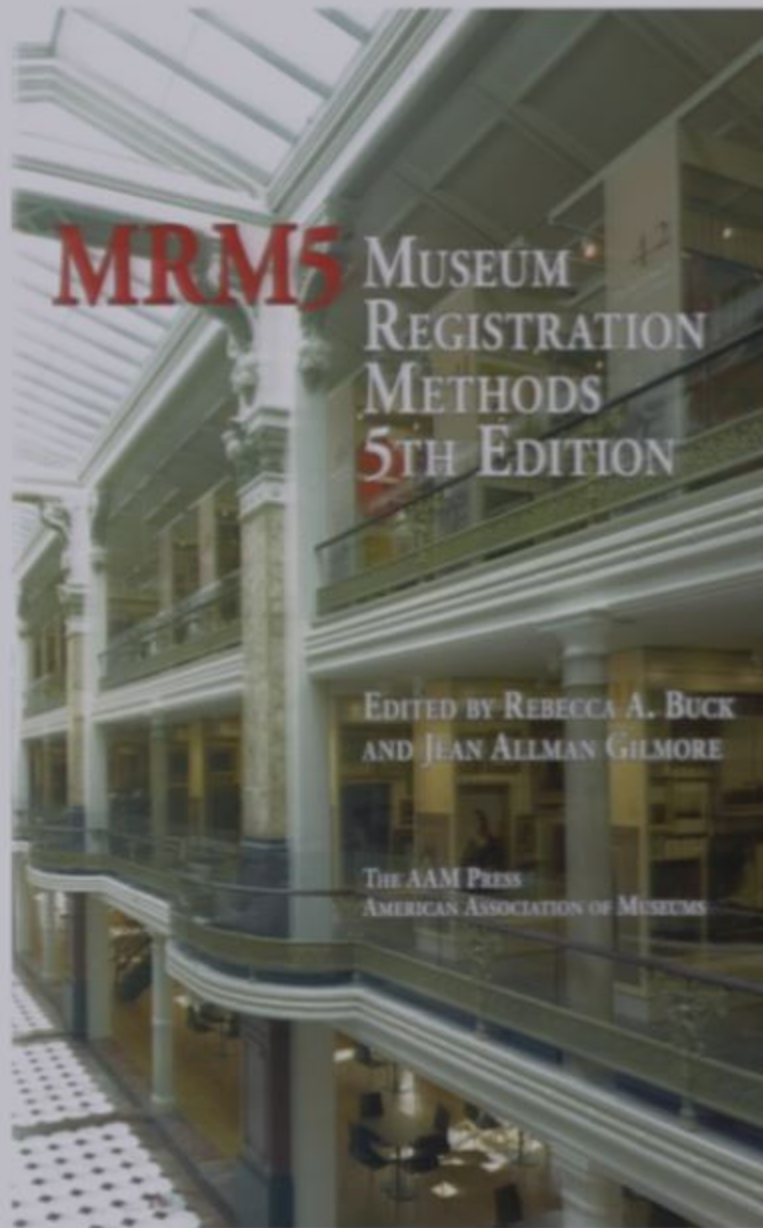

**MRM5** MUSEUM  
REGISTRATION  
METHODS  
5TH EDITION

EDITED BY REBECCA A. BUCK  
AND JEAN ALLMAN GILMORE

THE AAM PRESS  
AMERICAN ASSOCIATION OF MUSEUMS



The Museum of Modern Art, NY

Photo: © 2015 Kohn Pedersen Fox



**PERFORMANCE**

**MUSEUM**

## Kevin Beasley

*I Want My Spot Back*, 2011-2012

Performance with 39 processed a cappella tracks (28 min.), sealed letter

Dimensions variable

Fund for the Twenty-First Century



**Roman Ondák**

*Measuring the Universe, 2007*

Performance

Fund for the Twenty-First Century



Photos: ©The Museum of Modern Art, NY

**Jennifer Allora and Guillermo Calzadilla**

*Stop, Repair, Prepare: Variations on "Ode to Joy" for a Prepared Piano, 2008*

Prepared Bechstein piano, pianist (Terezija Cukrow shown)  
Gift of the Julia Stoschek Foundation, Düsseldorf



Artist's Choreographic note,  
*Performance 9: Allora and Calzadilla,*  
December 8, 2010-January 10, 2011,  
The Museum of Modern Art, NY

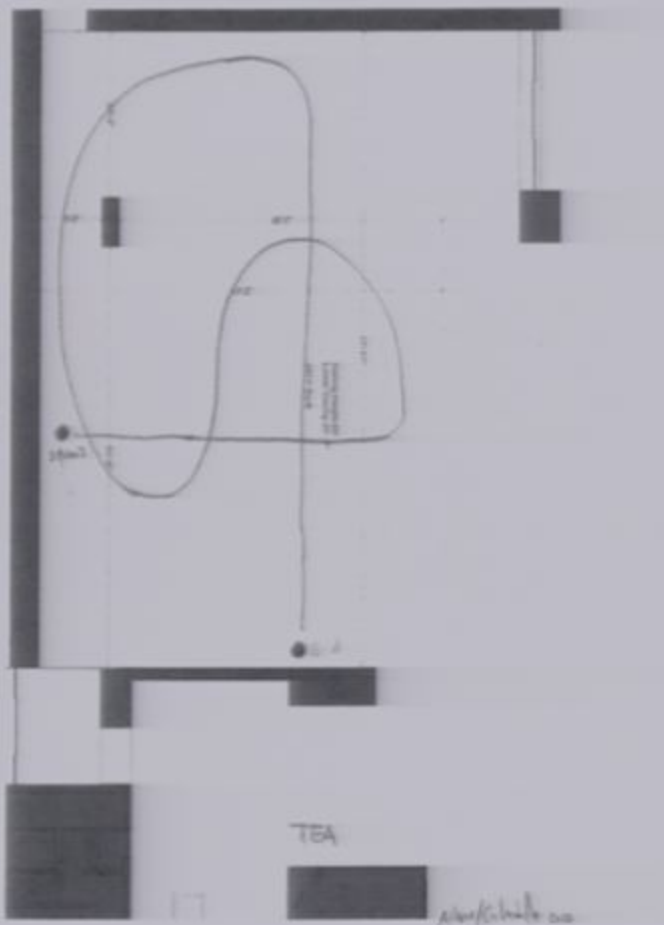



## Performance Worksheet covers:

- Curatorial project description with budget research including fabrication, shipping and travel costs
- Installation instructions, specifications for performers and props before, during and after
- Audio Visual /Art Handling requirements
- Graphics, Imaging needs
- Operations, Security, Visitor Services concerns
- Communication/Development
- Education, Website, Digital Presence

## Milan Knížák

### *Performance Files*, 1962–85

101 files with scores and photographs  
dimensions vary

The Gilbert and Lila Silverman Fluxus Collection Gift

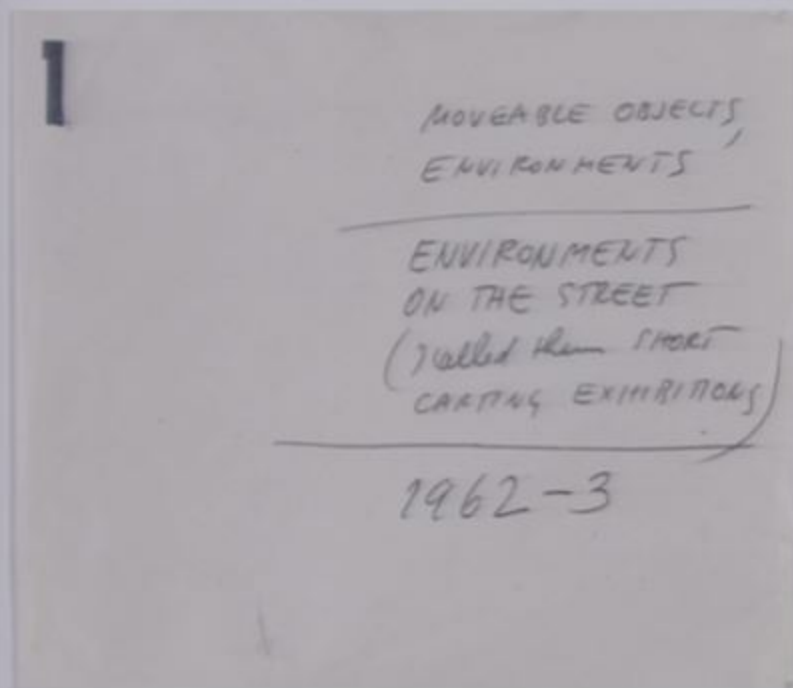

## Milan Knížák

### *I Scattered on a Prague Street a Great Amount of Papers* (from *Performance Files*), 1965

Two photocopies

The Gilbert and Lila Silverman Fluxus Collection Gift

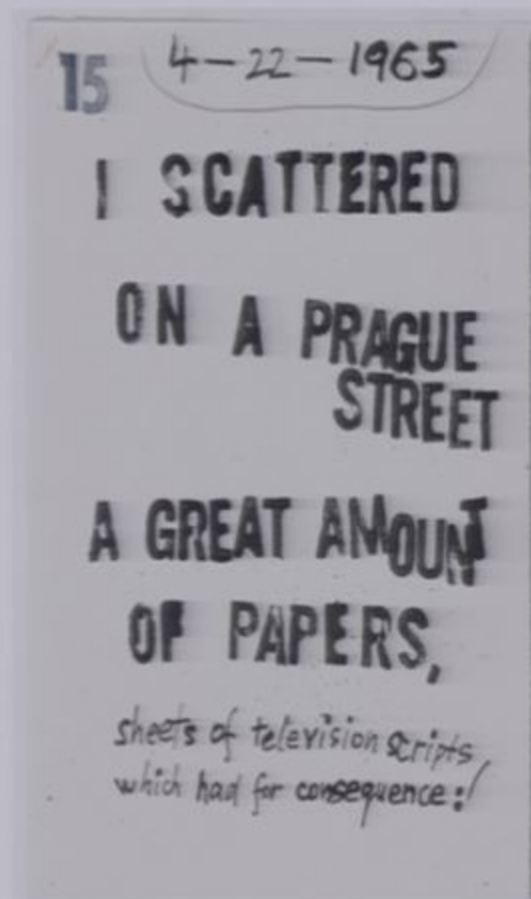

## James Lee Byars

Memorandum, discussing Byars anonymous gift, from Dorothy C. Miller to the James Byars File, March 15, 1965

The Museum of Modern Art Archives, New York

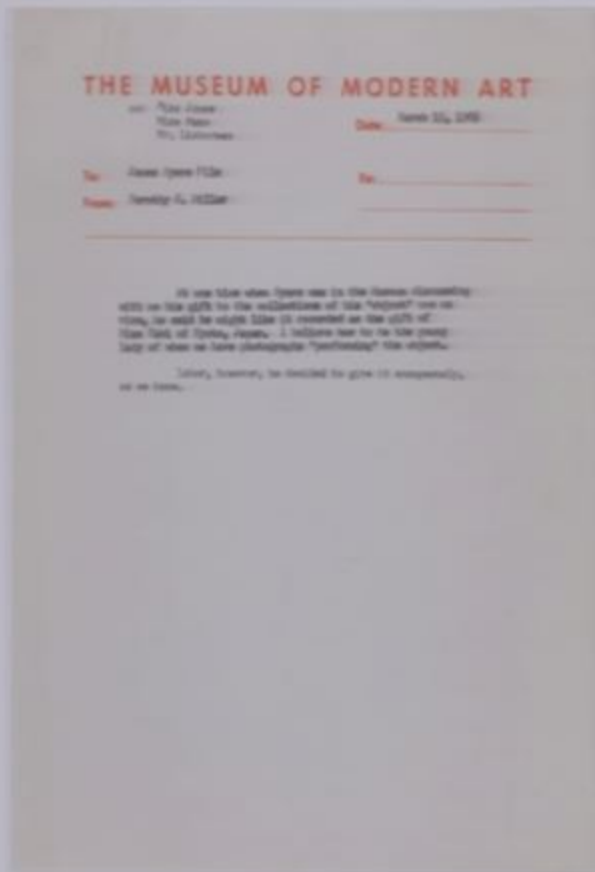

Exhibition Invitation to the T. V. Ball

Envelope containing red folded star-shaped invitation paper-clipped to pink card. 1970

Herman and Nicole Daled Papers, partial gift of the Daled Collection

The Museum of Modern Art Archives, New York

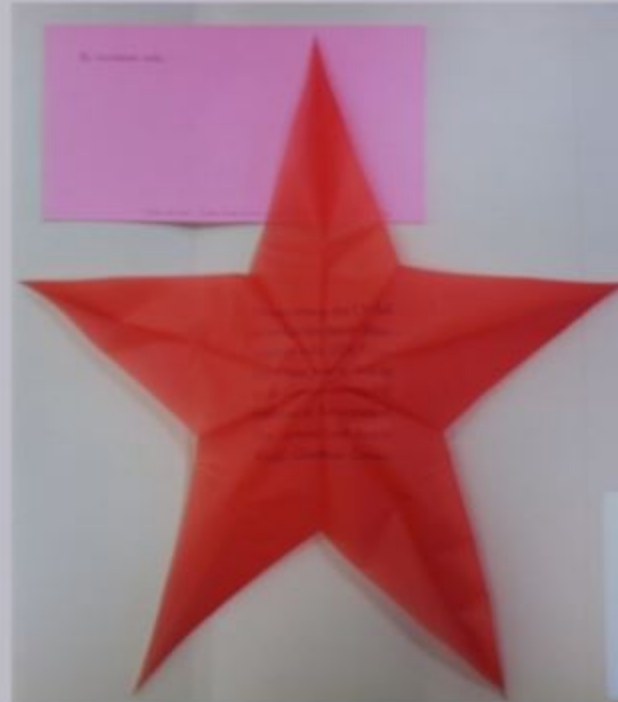

## James Lee Byars

### *The Mile Long Paper Walk*, 1964-65

Japanese handmade white flax paper, joined  
with rivets

Folded 12 x 70 3/4 x 4" (30.4 x 179.7 x 10.1 cm)

Unfolded 12" x 500' (30.4 cm x 152.4 m.)

weight 22 lbs (10.00 kg)

Gift of the artist



Lucinda Childs performing James Lee Byars, *The Mile Long Paper Walk*  
Hall of Sculpture, October 25, 1965, Carnegie Museum of Art.

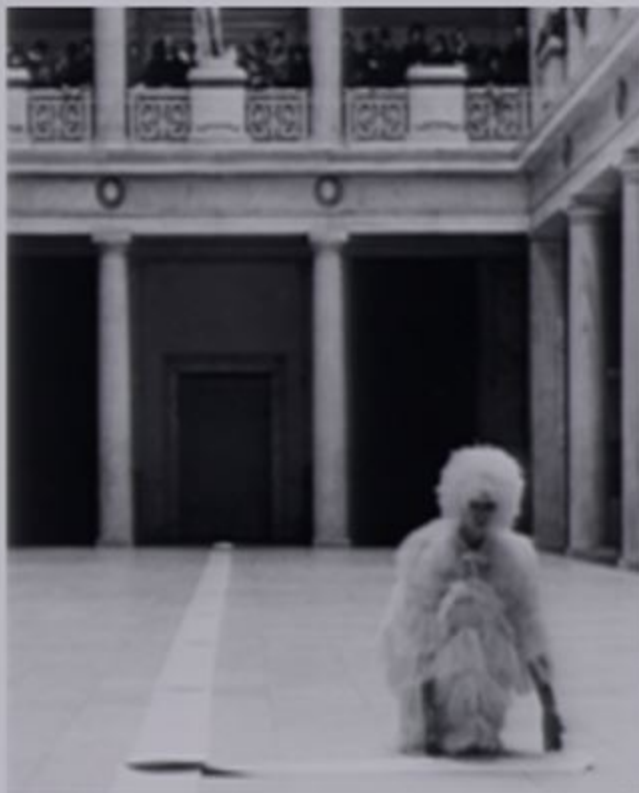

M.C.- BYARS

380.66

Caption on photo from artist:

" (Carnegie feather photo's)

" 1 by 500 feet in 75 sections connected by rivets (stacks to 1' by 6' by 4 inches) put out as a halo (100 feet) as a star, as any perimeter --- or maybe performed however --- this piece also may be hung by means of the hollow eye rivets. From left to right "

## James Lee Byars

### *The Mile-Long Paper Walk*, 1965–2014

Performed at The Museum of Modern Art, August 17, 2014 for the exhibition *James Lee Byars*

Performed by Katie Dorn; choreographic construction by Lucinda Childs.





Performed at The Museum of Modern Art, September 7, 2014  
for the exhibition James Lee Byars  
Performed by Jimmy Robert





Performed at The Museum of Modern Art, September 7, 2014  
for the exhibition James Lee Byars  
Performed by Jimmy Robert





## Paul Chan

*Waiting for Godot*, 2007

Props, archives materials

Dimensions variable

Acquired through the generosity of Maja Oeri and Hans Bodenmann



# CREATIVETIME

CREATIVETIME PRESENTS  
 FREE CLASSICAL THEATRE BY HAROLD  
 PINTER'S WAITING FOR GODOT IN NEW ORLEANS

WEDNESDAY 7 & 8, 2007 LOWER NINTH WARD  
 MONDAY 9 & 10, 2007 GENTILLY



Let us all wonder why there is such a silence of peace, immediately let us all  
 remember, when we have the chance to be the same day that we are waiting  
 for the man that we have never seen. There will be one who  
 needs work to be done. It is to be done by the same person. There will be  
 no other person to see him. Let us all wonder why there is such a  
 silence of peace, immediately let us all remember, when we have the chance  
 to be the same day that we are waiting for the man that we have never seen.  
 —Waiting for Godot by Samuel Beckett

Creative Time is pleased to announce a free performance of Harold Pinter's Waiting for Godot, a play that  
 has been produced in over 50 countries. Pinter's play is a masterpiece of modern drama. It is a play that  
 is both funny and serious. It is a play that is both simple and complex. It is a play that is both  
 easy and difficult. It is a play that is both a comedy and a tragedy. It is a play that is both a  
 masterpiece and a work of genius. It is a play that is both a classic and a modern masterpiece.  
 —Waiting for Godot by Harold Pinter

CREATIVETIME  
 111 W. 15th St., New York, NY  
 212.929.5000

Creative Time Press release and  
 announcements advertising  
 "Waiting for Godot"

Free Performance! World-Class Entertainment!

## Waiting for GODOT

By Samuel Beckett  
 A tragicomedy in two acts



NOVEMBER 2 & 3  
 7pm, Lower Ninth Ward

NOVEMBER 9 & 10  
 7pm, Gentilly

Direction of Phil Dr. & Robert E. Lee High

★ Starring ★

Wendell Pierce (star of HBO's The Wire)

J Kyle Manzay ★ T. Ryder Smith ★ Mark McLaughlin

Michael Pepp ★ Tony Felix

Director: Christopher McElroy  
 Artistic Director: Paul Chan

All performances are OUTDOORS and FREE and OPEN to the public.  
 For more information, please call (504) 467-1118

Presented by Creative Time in collaboration with the Classical Theatre of Harlem and New Orleans Partners. University of New Orleans, Tulane University, Orange University, HBCU High School, Luther High School, Trinity High School, Jean-Louis High School, students at the Center for Neighborhood Youth Project, The Park, Renaissance Park, Neighborhood Ambassador Robert Lynn Green Sr. and the rest of the good people in the city of New Orleans. ★

FREE PERFORMANCE!

## WAITING FOR GODOT



By Samuel Beckett, a tragicomedy in two acts

Starring: Wendell Pierce, J Kyle Manzay,  
 T. Ryder Smith, Mark McLaughlin,  
 Michael Pepp, and Tony Felix  
 Directed by Christopher McElroy, Artistic Director: Paul Chan

### LOWER NINTH WARD

WEDNESDAY & THURSDAY  
**NOVEMBER 2 & 3**  
 7:00 PM

### GENTILLY

MONDAY & TUESDAY  
**NOVEMBER 9 & 10**  
 7:00 PM

Presented by Creative Time in collaboration with the  
 Classical Theatre of Harlem & New Orleans Partners

UNIVERSITY OF NEW ORLEANS, TULANE UNIVERSITY, HBCU HIGH SCHOOL, LUTHER HIGH SCHOOL, TRINITY HIGH SCHOOL, JEAN-LOUIS HIGH SCHOOL, STUDENTS AT THE CENTER FOR NEIGHBORHOOD YOUTH PROJECT, THE PARK, RENAISSANCE PARK, NEIGHBORHOOD AMBASSADOR ROBERT LYNN GREEN SR. AND THE REST OF THE GOOD PEOPLE IN THE CITY OF NEW ORLEANS.

All performances are FREE & open to the public. For more info, please call (504) 467-1118.



One of several photos of signage, streets of New Orleans, setting of play, audience, actors and interactive classes during production of *"Waiting for Godot"*

Printed map "Neighborhoods in Orleans Parish"  
and Hand-drawn street map with directions

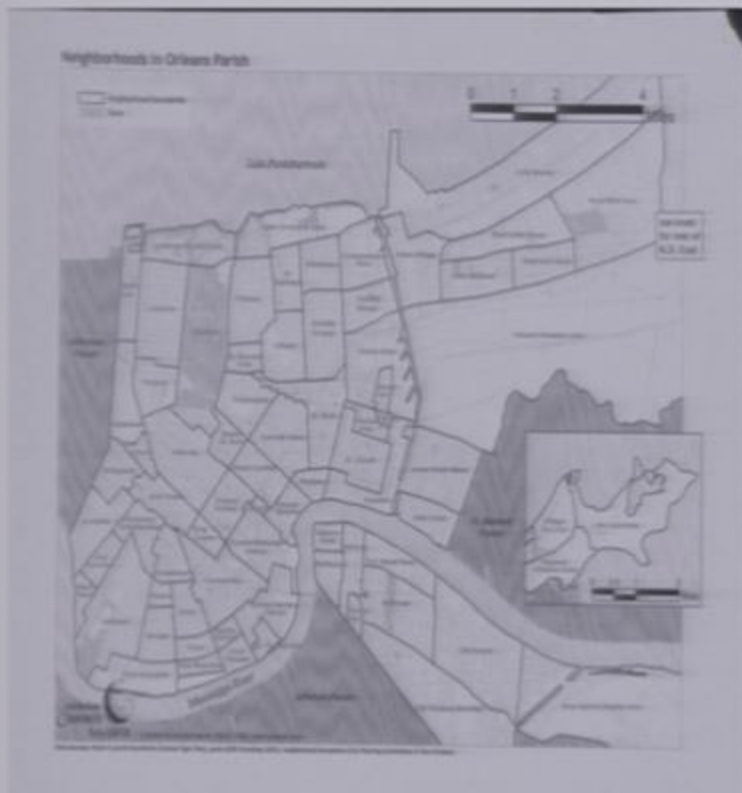

Color scan of pencil drawings, signed by the artist.



## DETAIL

Paul Chan

*Waiting for Godot*, 2007





## DETAIL

Paul Chan

*Waiting for Godot*, 2007



Photo: © The Museum of Modern Art, NY





**CONTEMPORARY ART**

**MUSEUM**

# Former common practice

## Issue

- My sculpture weighs 40,000 lbs
- My painting is 30 feet long
- My sculpture is made of wool
- My sculpture is made of lightbulbs

## Questions

- Is the floor rated for the weight?
- How much will rigging cost?
- Can it fit in the elevator?  
How about through doors?
- Will we have issues with bugs?
- Will the emitted light affect nearby artworks?



## Robert Gober

### *Untitled*, 2003-2005

Plaster, fir, wool, linen, photolithograph on acid-free paper, oil paint, semi-gloss enamel paint, water-color, pastel, graphite, bronze, cast plastic, polyethylene, lead crystal, fiberglass, nickel plated bronze, wood, water, recycling pumps, stoneware, urethane, rubber, cement, feather re-creation of American Robin, blown glass, Flashe paint, aluminum, pewter, beeswax, human hair, pigment, socks, and shoes

Dimensions variable Gift of Maja Oeri and Hans Bodenmann





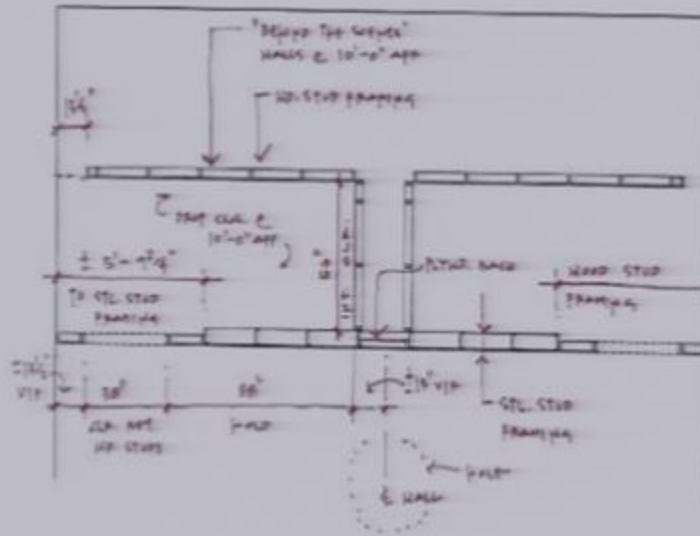

PLAN: CHEST / TUB WALL

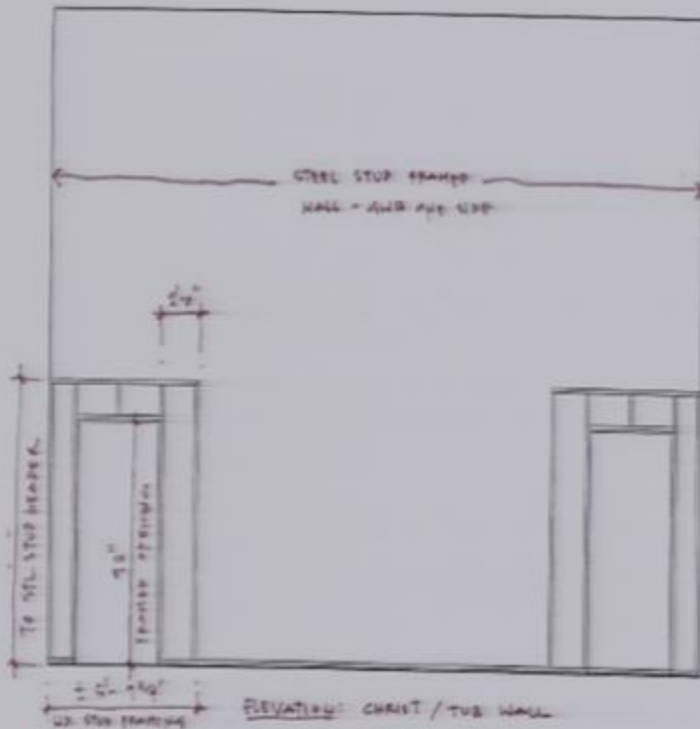

ELEVATION: CHEST / TUB WALL

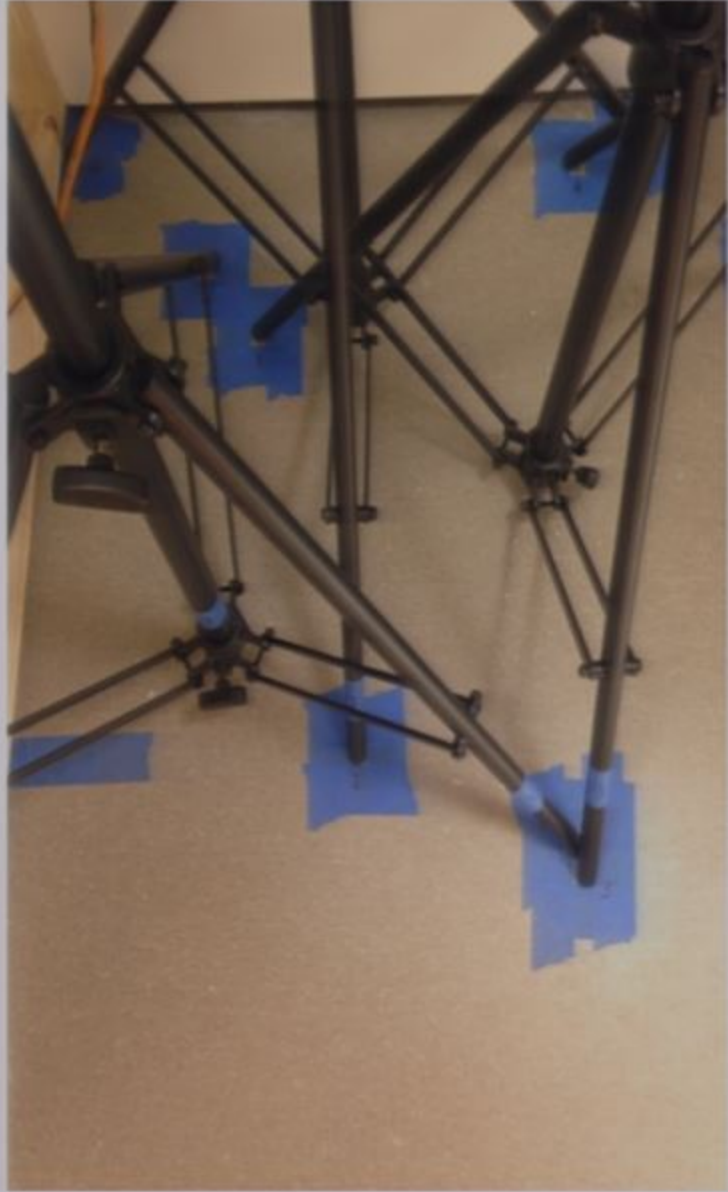





# What does it take?



# Robert Gober, *Untitled*

## Issues

- The sculpture requires running and standing water
- Work is installed adjacent to paper works and sculptures from a variety of lenders
- Need to break through the floor of the museum

## Questions

- How do we cycle it?
- Will algae become an issue?
- Will it raise humidity and affect nearby artworks?
- How will visitors interact?
- Can we install it or do we require plumbers?
- Special equipment not originally purchased?
- Conservation issues?
- Can you turn it off?





# Robert Gober

*Work 1976 - 2007*

Schaulager, Basel

May 12 - October 14, 2007



ROBERT GOBER

THE HEART IS NOT A METAPHOR



MoMA

# Robert Gober

*The Heart is Not a  
Metaphor*

Museum of Modern Art

October 4, 2014–January 18, 2015



DETAIL  
**Robert Gober, *Untitled***









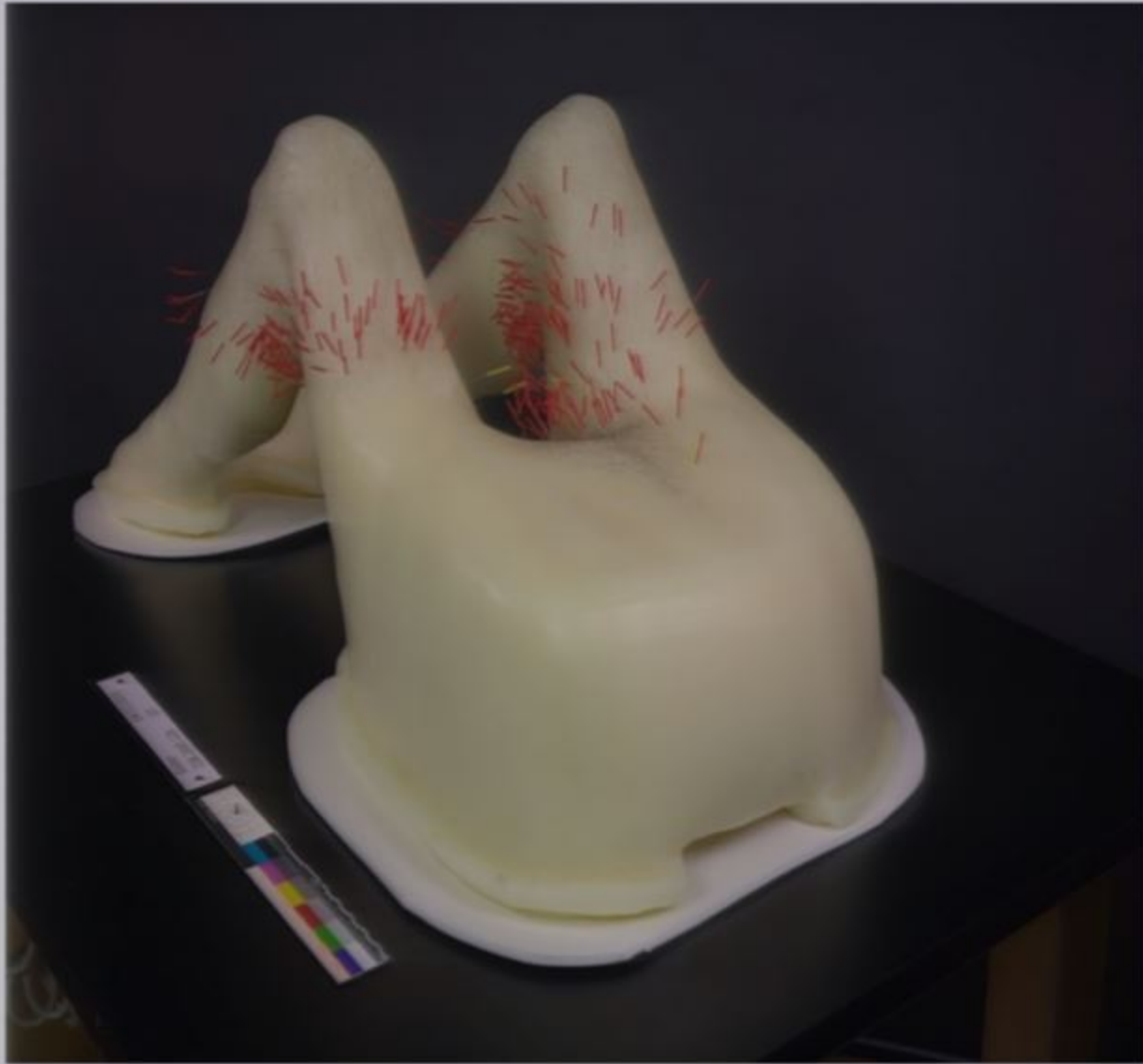





**Josh Kline**

*Skittles*, 2014

Commercial refrigerator, light box and blended liquids in bottles

86 1/2 x 127 1/2 x 41" (219.7 x 323.9 x 104.1 cm)

Fund for the Twenty-First Century

Image: © Yuko Torihara, Canal 47, NY





tourism  
starbucks  
sunglasses  
metrocard  
hotel soap  
cupcake  
cheesecake  
cronut

tourism  
starbucks  
sunglasses  
metrocard  
hotel soap  
cupcake  
cheesecake  
cronut

tourism  
starbucks  
sunglasses  
metrocard  
hotel soap  
cupcake  
cheesecake  
cronut

tourism  
starbucks  
sunglasses  
metrocard  
hotel soap  
cupcake  
cheesecake  
cronut







**Josh Kline**

*Skittles*, 2014

Commercial refrigerator, light box and blended liquids in bottles

86 1/2 × 127 1/2 × 41" (219.7 × 323.9 × 104.1 cm)

Fund for the Twenty-First Century

Image: © Yuko Torihara, Canal 47, NY

Plan for the future

Document and create  
existing work

Physical Context

Artist intent

Future  
Transformation



**INSTALLATION  
MANAGEMENT**

**MUSEUM**



**INSTALLATION  
MANAGEMENT**

**MUSEUM**

Cai Guo-Qiang





Photo: ©The Museum of Modern Art, NY

# Installation Instructions on File

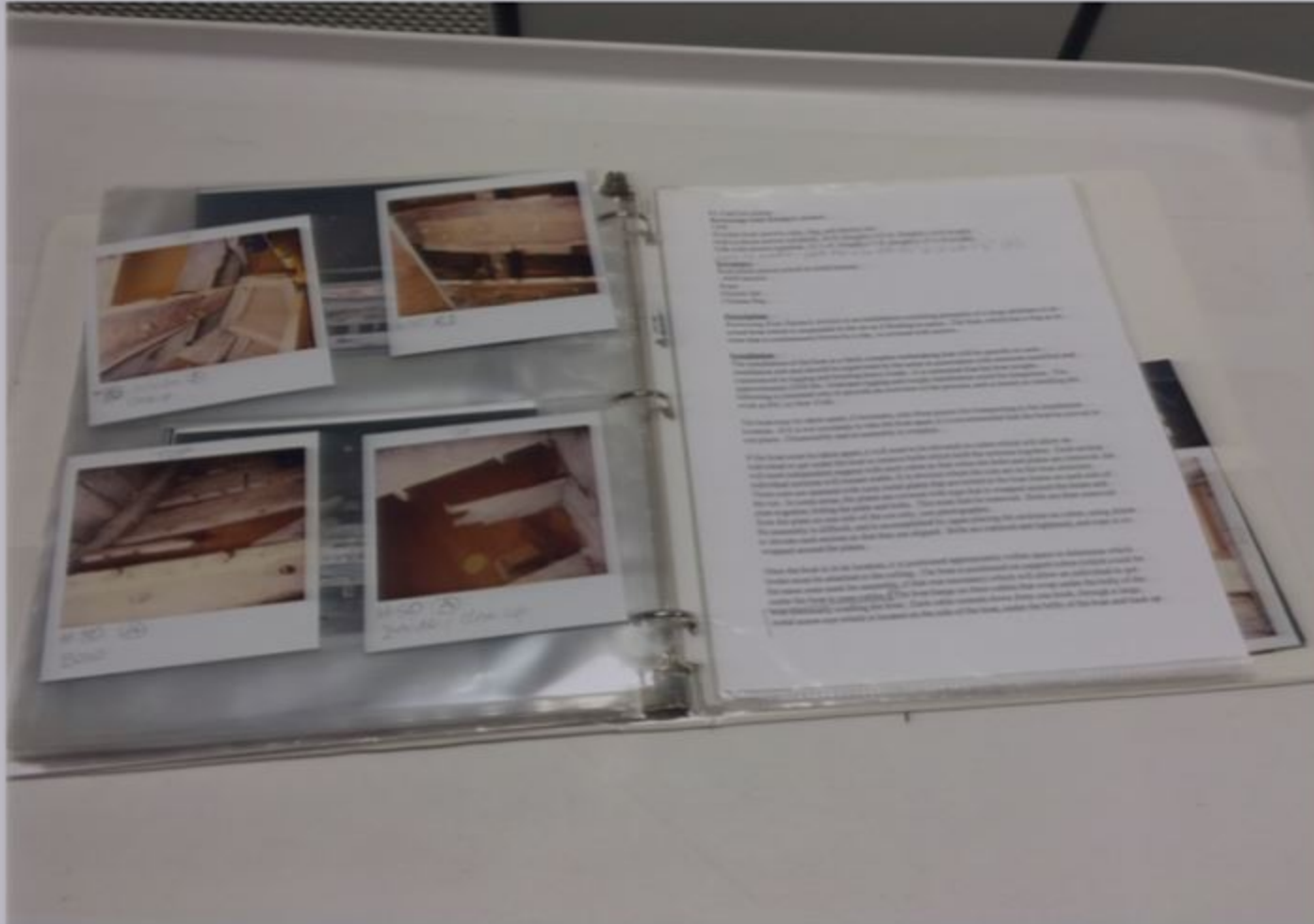

# CEMS Standards and Data Entry

The Museum System - MoMA's Collection and Exhibition Management System (CEMS) - [Components]

File Query Report Related Tools Maintenance



## Painting & Sculpture

### 318.1999

### *Borrowing Your Enemy's Arrows*

Artist: Cai Guo-Qiang

1998

Wood boat, canvas sail, arrows, metal, rope, Chinese flag, and electric fan

Boat approximately 60" x 23' 7" x 7' 6" (152.4 x 720 x 230 cm), each arrow approximately 24" (62 cm)

Component	Component Name	Count	Active	
318.1999.a	boat	1	<input checked="" type="checkbox"/>	Part of artwork
318.1999.b	Arrows	1800	<input checked="" type="checkbox"/>	Part of artwork
318.1999.c.x1	flag	1	<input checked="" type="checkbox"/>	Part of artwork
318.1999.c.x2	spare flag	1	<input checked="" type="checkbox"/>	Part of artwork
318.1999.CR1	Crate 1/7 (boat)	1	<input checked="" type="checkbox"/>	Accessory
318.1999.CR2	Crate 2/7 (900 arrows)	1	<input checked="" type="checkbox"/>	Accessory
318.1999.CR3	Crate 3/7 (900 arrows)	1	<input checked="" type="checkbox"/>	Accessory
318.1999.CR4	Crate 4/7 (rope)	1	<input checked="" type="checkbox"/>	Accessory
318.1999.CR5	Crate 5/7 (rope)	1	<input checked="" type="checkbox"/>	Accessory
318.1999.CR6	Crate 6/7 (utility crate)	1	<input checked="" type="checkbox"/>	Accessory
318.1999.CR7	Crate 7/7 (bows)	1	<input checked="" type="checkbox"/>	Accessory
318.1999.d	wood rudder	1	<input checked="" type="checkbox"/>	Part of artwork
318.1999.e	fan	1	<input checked="" type="checkbox"/>	Part of artwork
318.1999.HW	Hardware (Hanging Bolts)	1	<input checked="" type="checkbox"/>	Accessory
318.1999.MI	bows (for optional display)	1	<input checked="" type="checkbox"/>	Part of artwork

Description

Notes

Physical Description

Boxart crate, 79 x 295 x 102", constructed 8/08

Component Barcode

ED288188D1C62

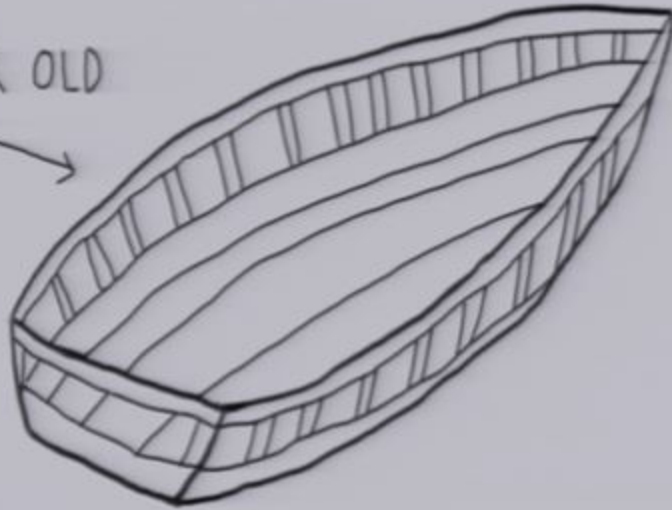

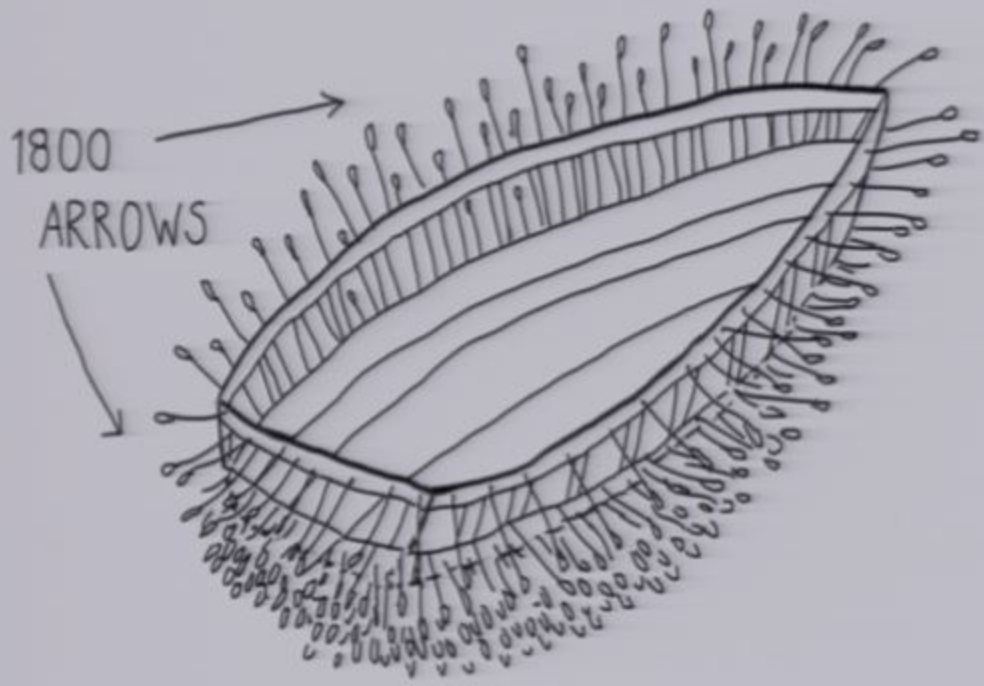

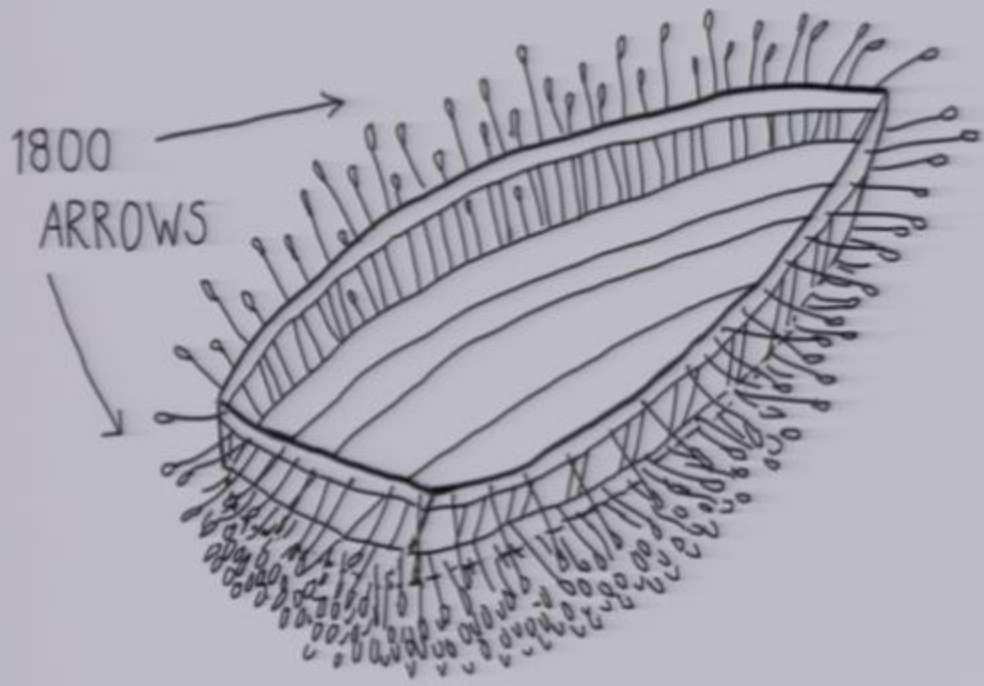

Photo: ©The Museum of Modern Art, NY

100 YEAR OLD  
BOAT →









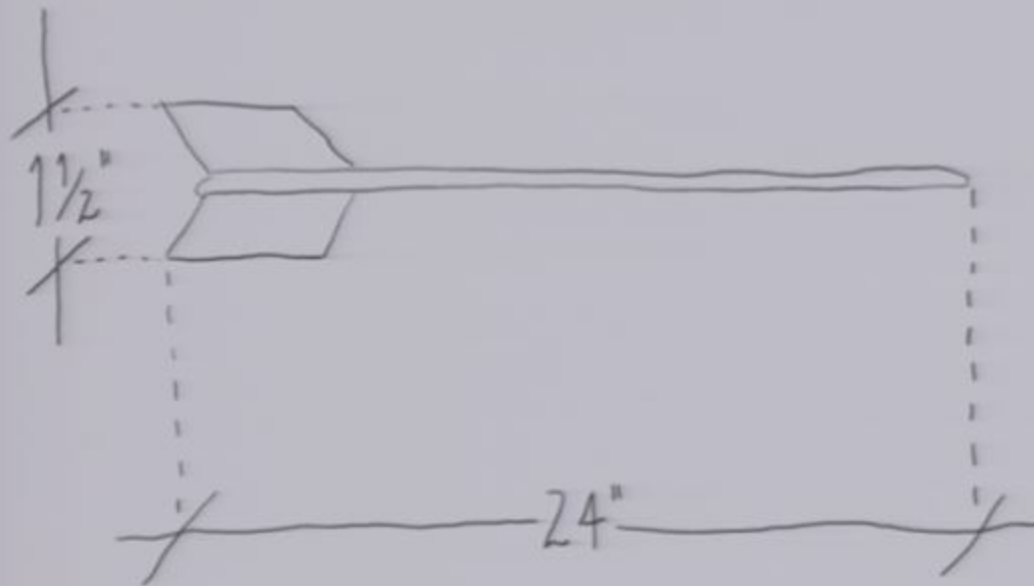

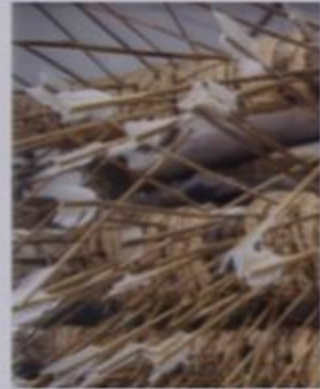
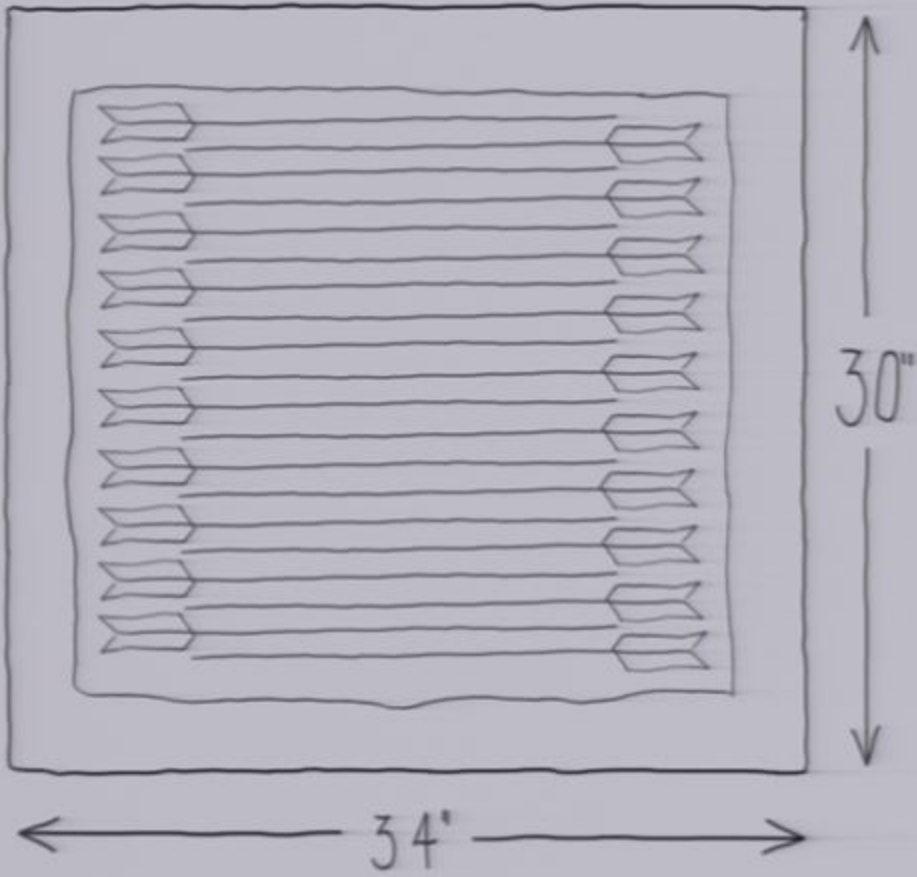

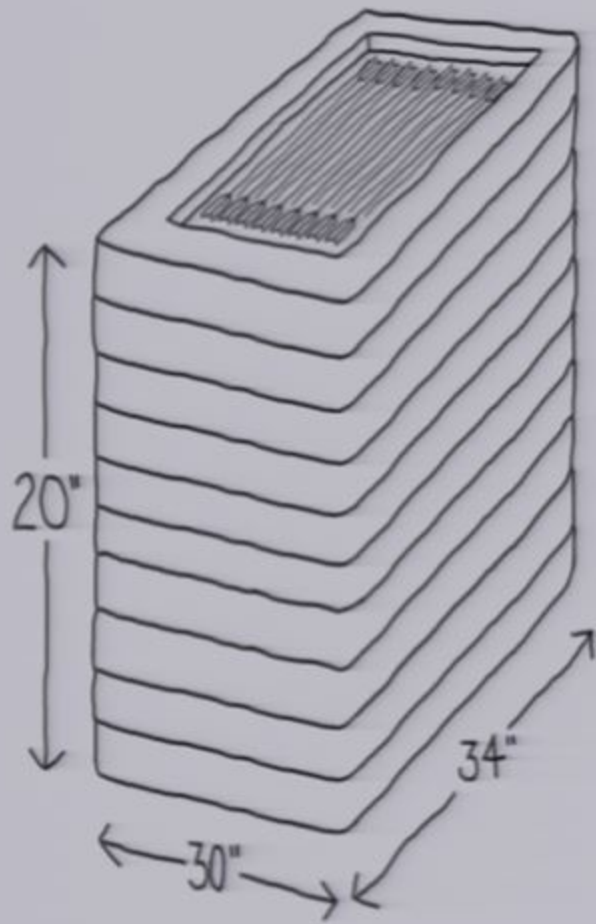





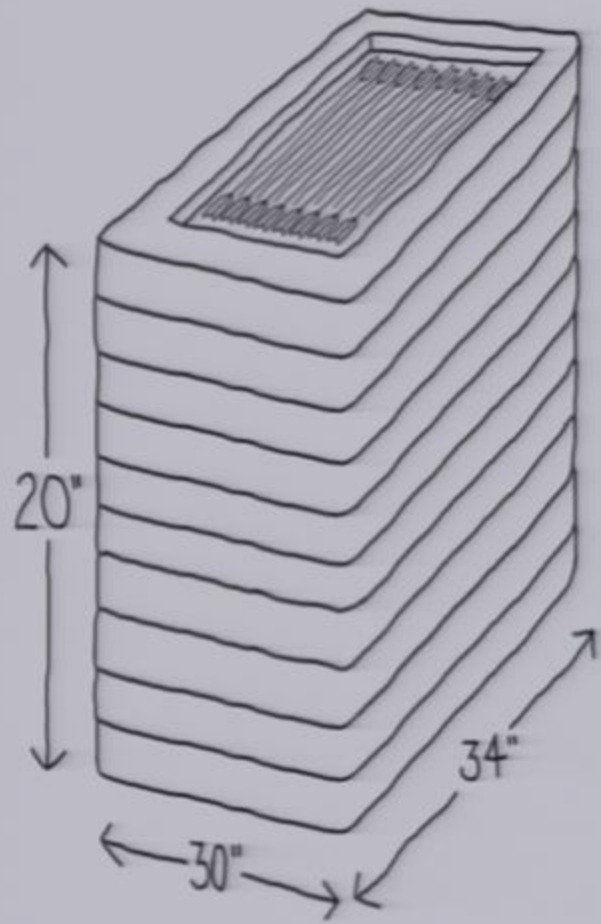

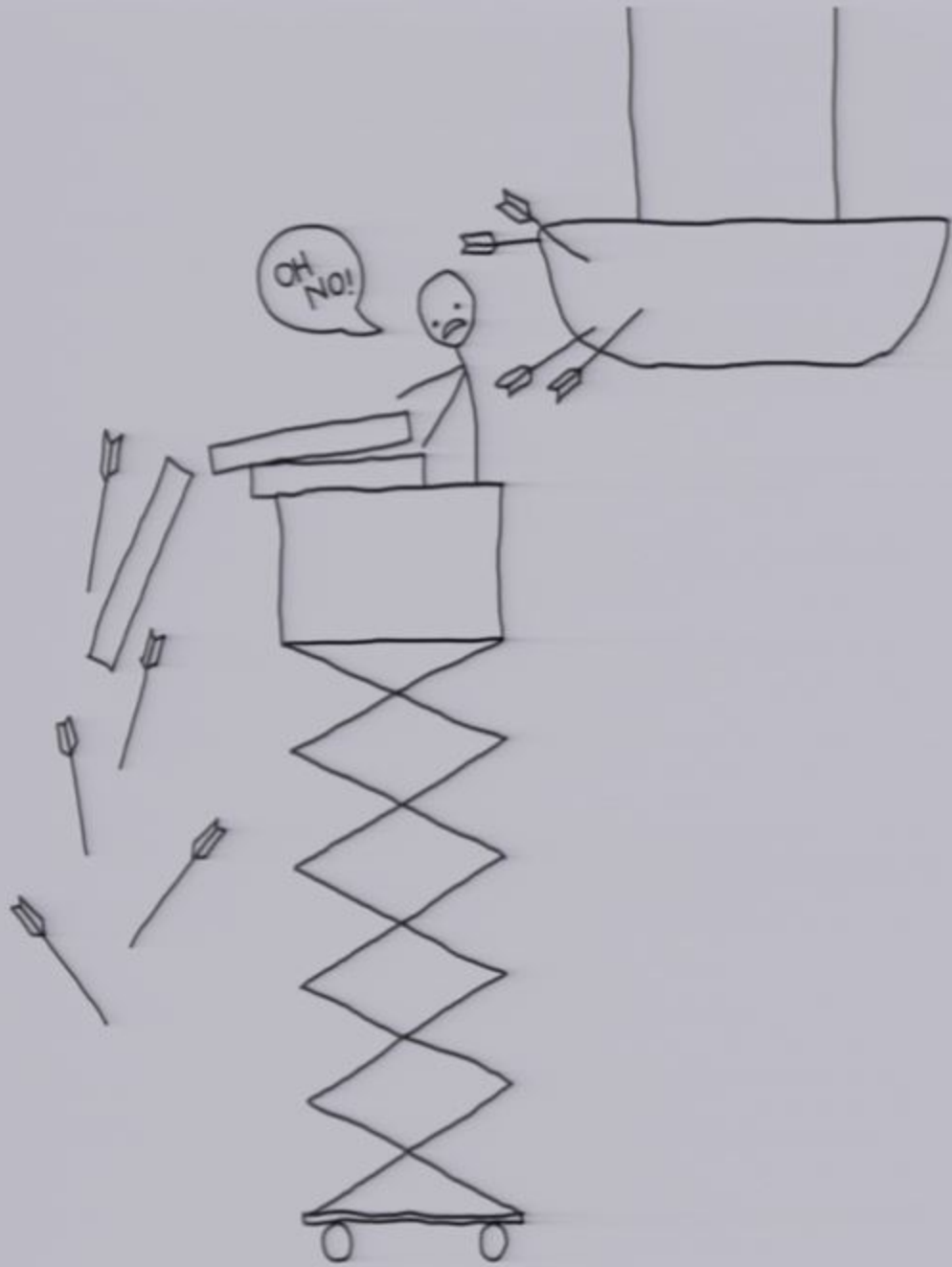

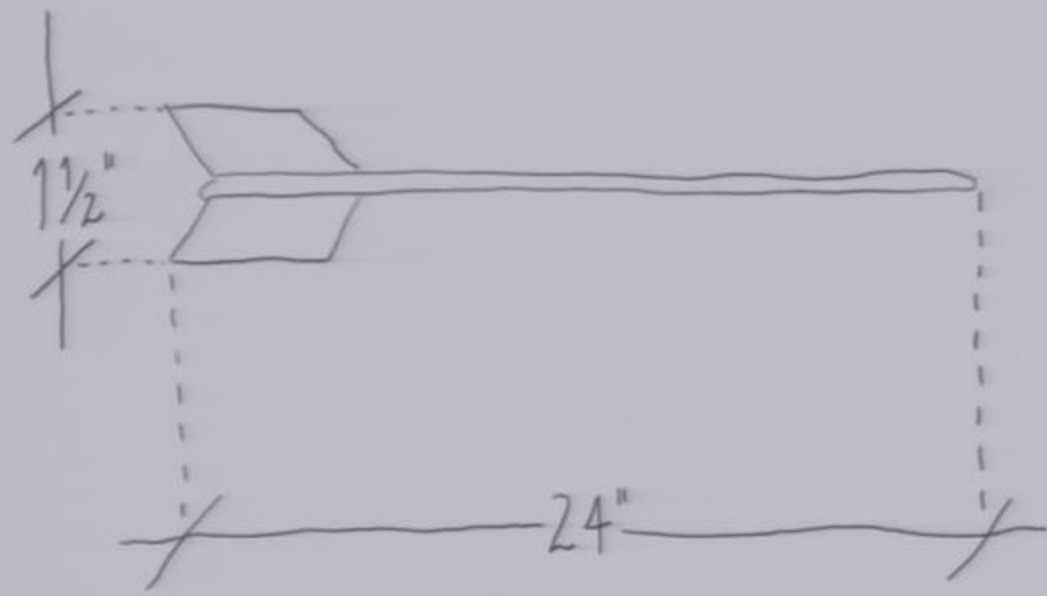

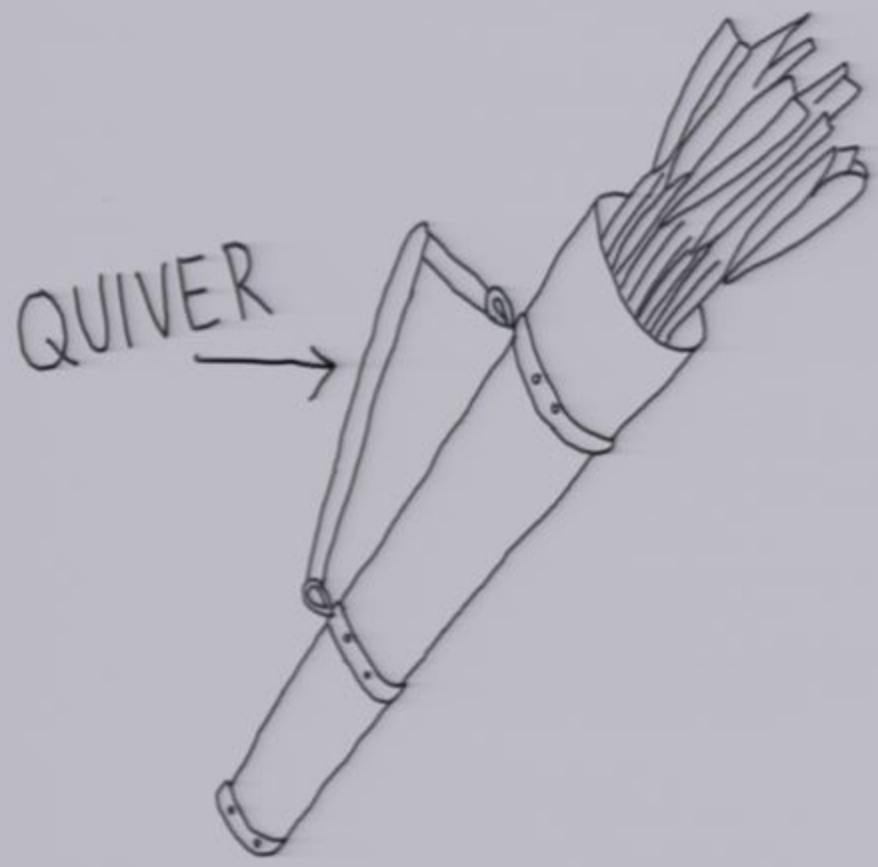

FOAM  
QUIVER

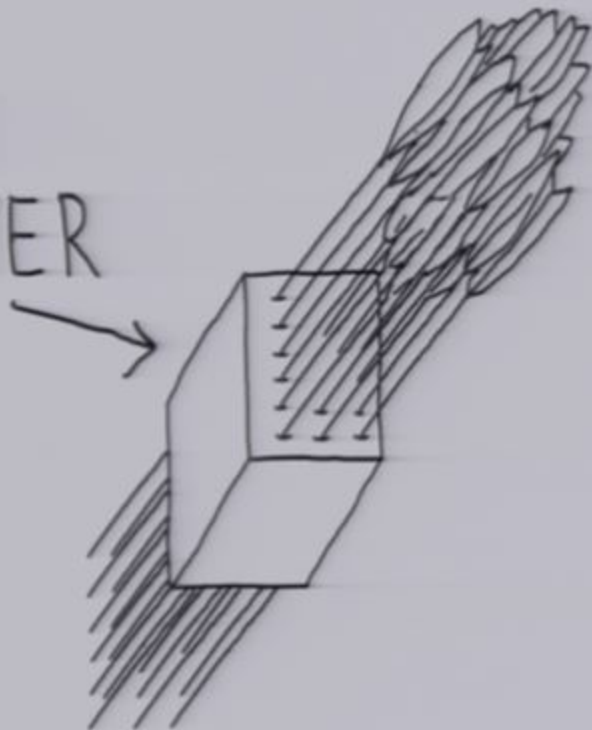

RACK

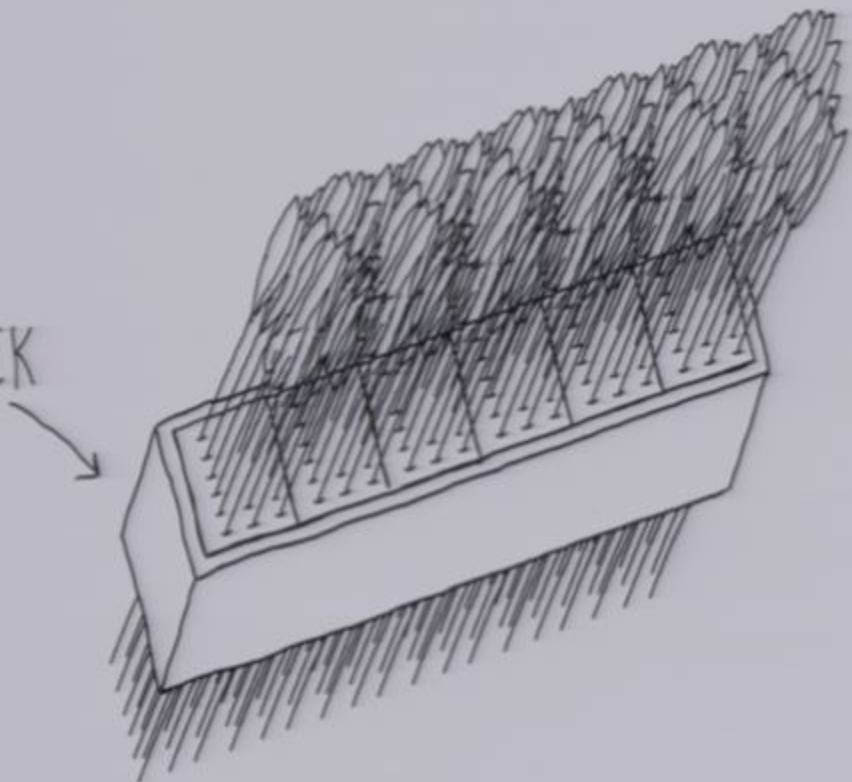

TRACK  
BRACES

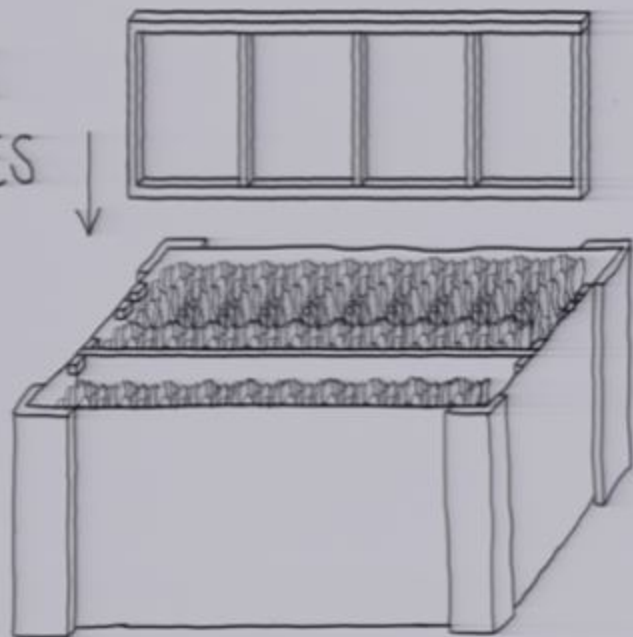



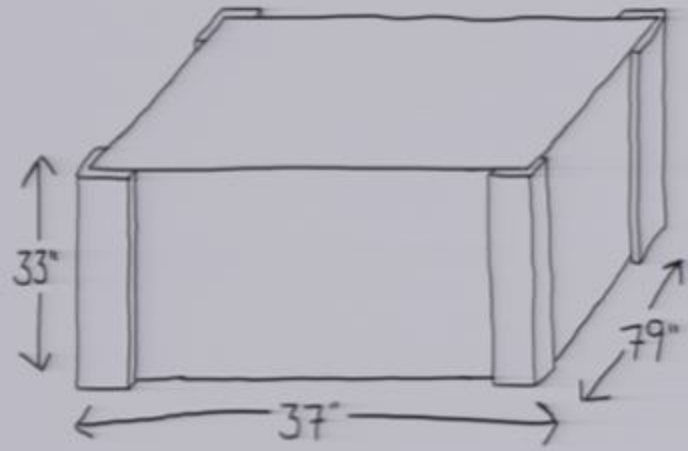
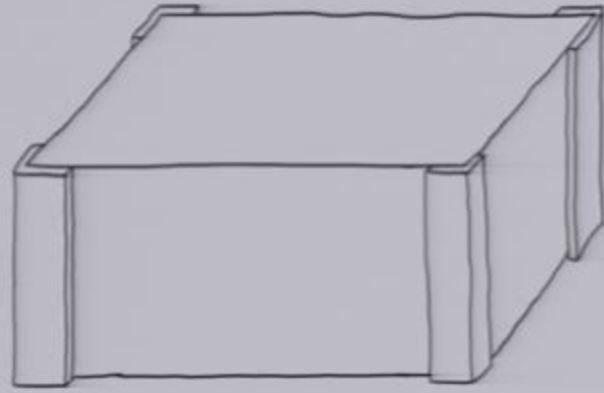

IT'S  
STILL A  
LOT OF  
WORK!



100 YEAR OLD  
BOAT →

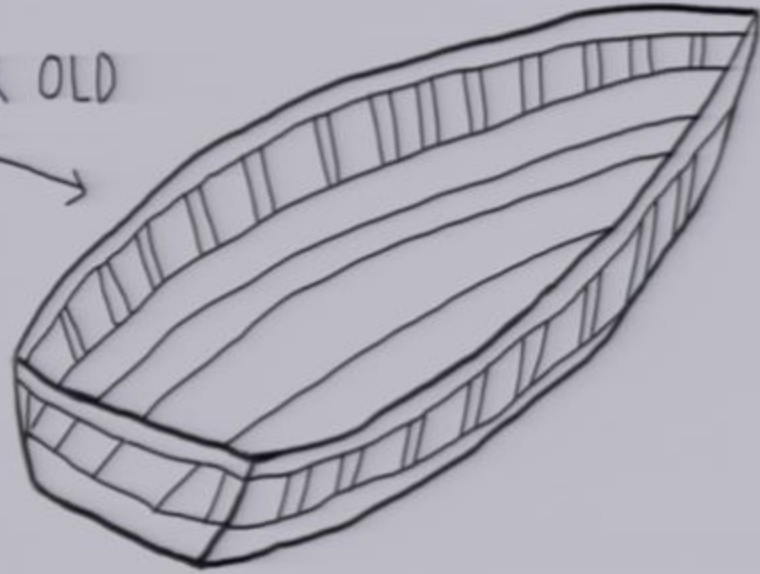

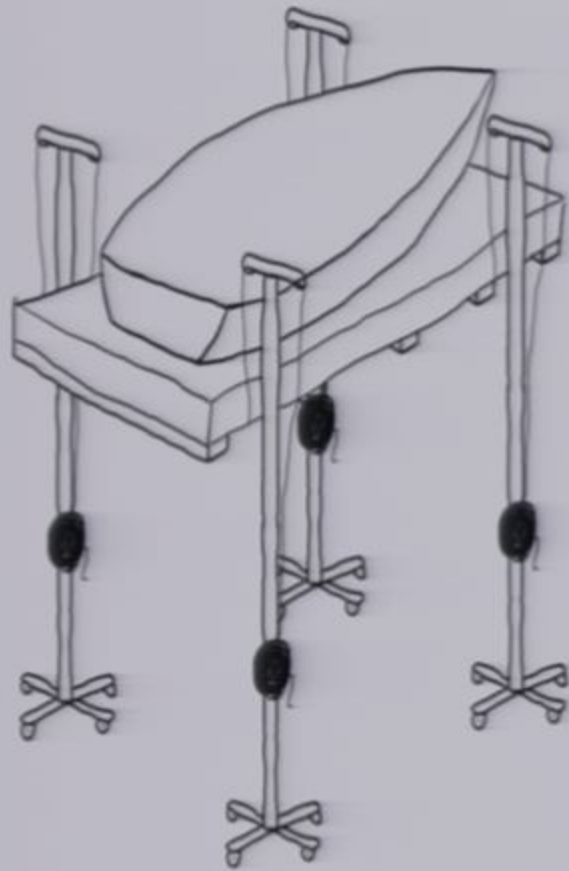

TRAY FOR RIGGING



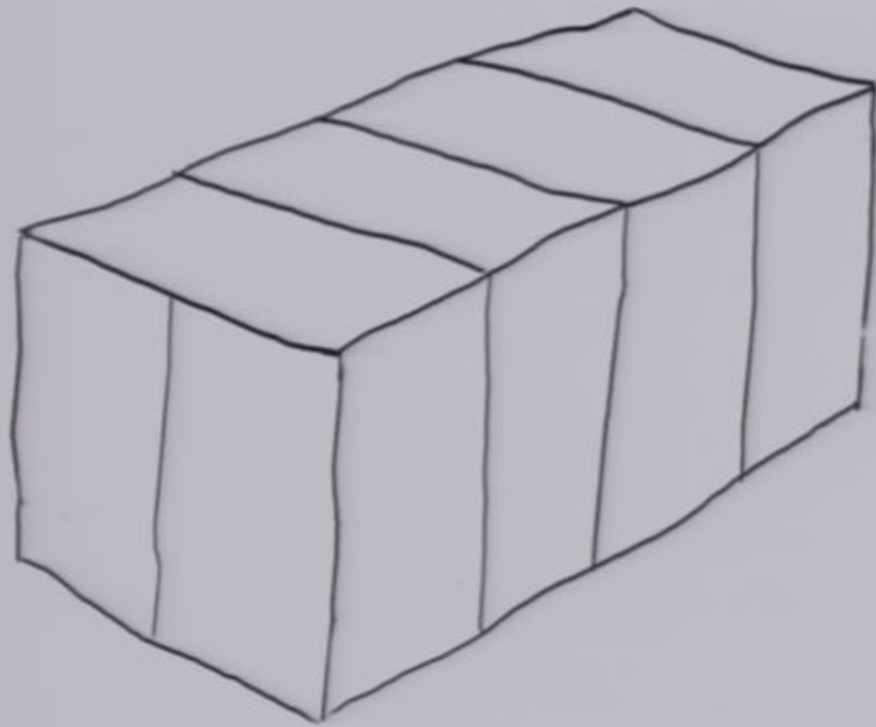

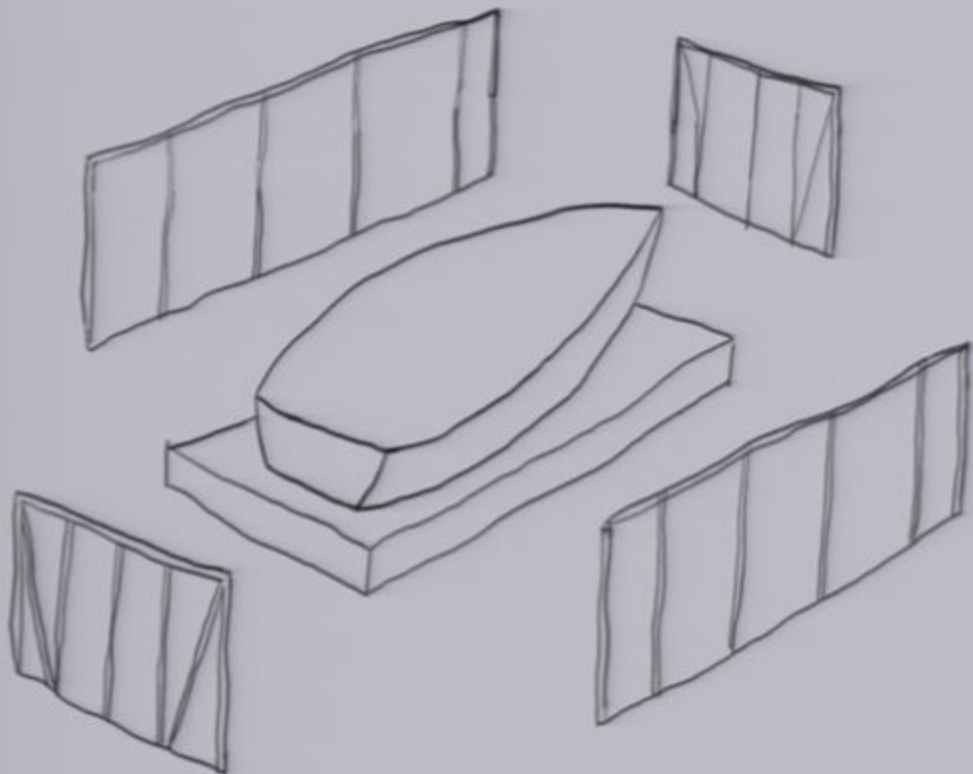

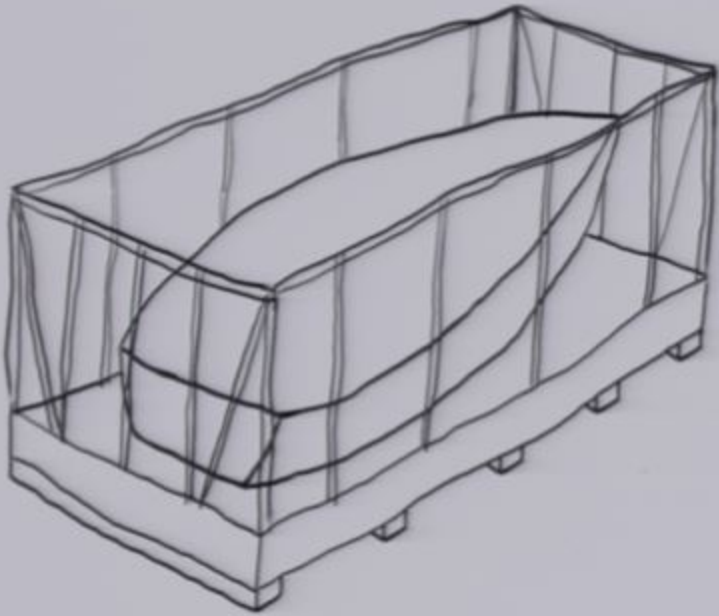

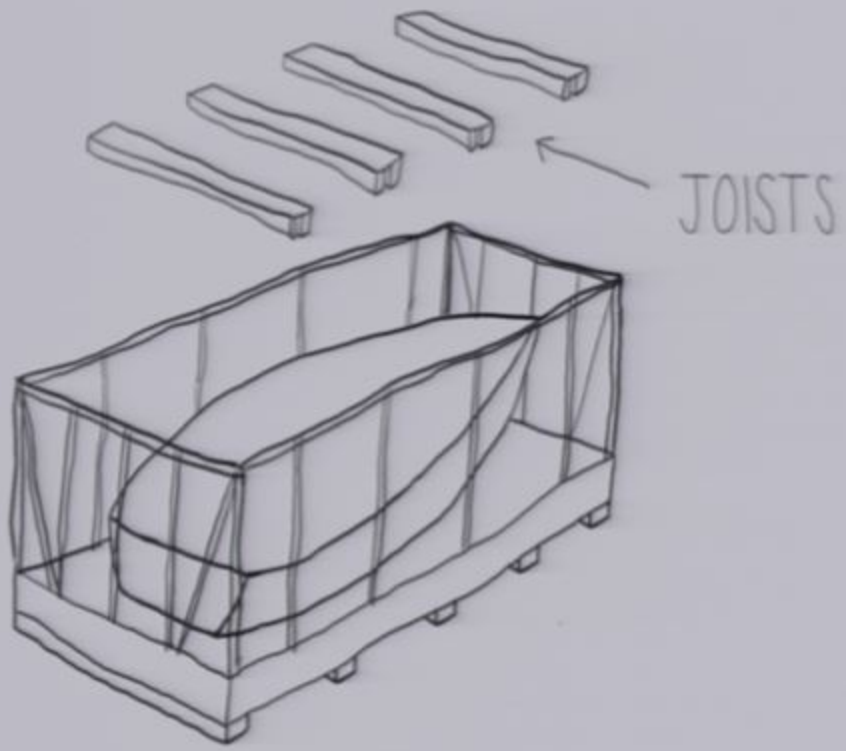



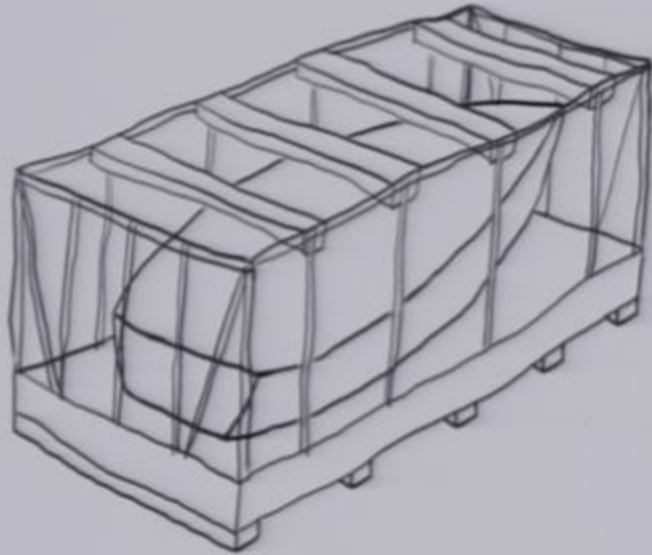

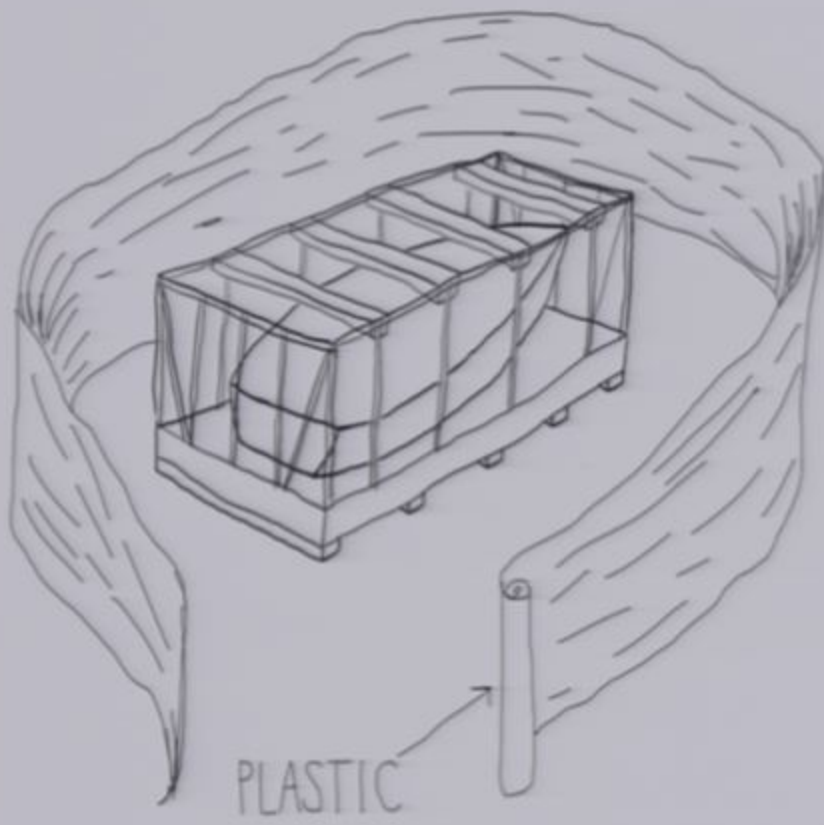

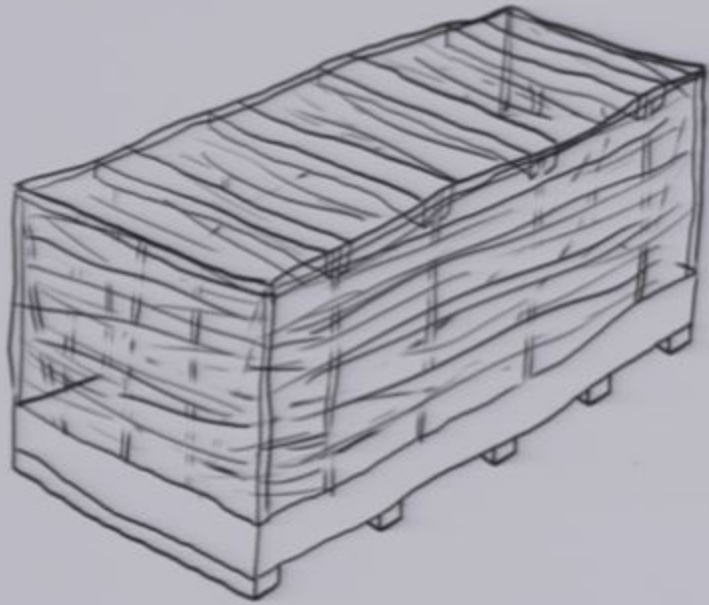

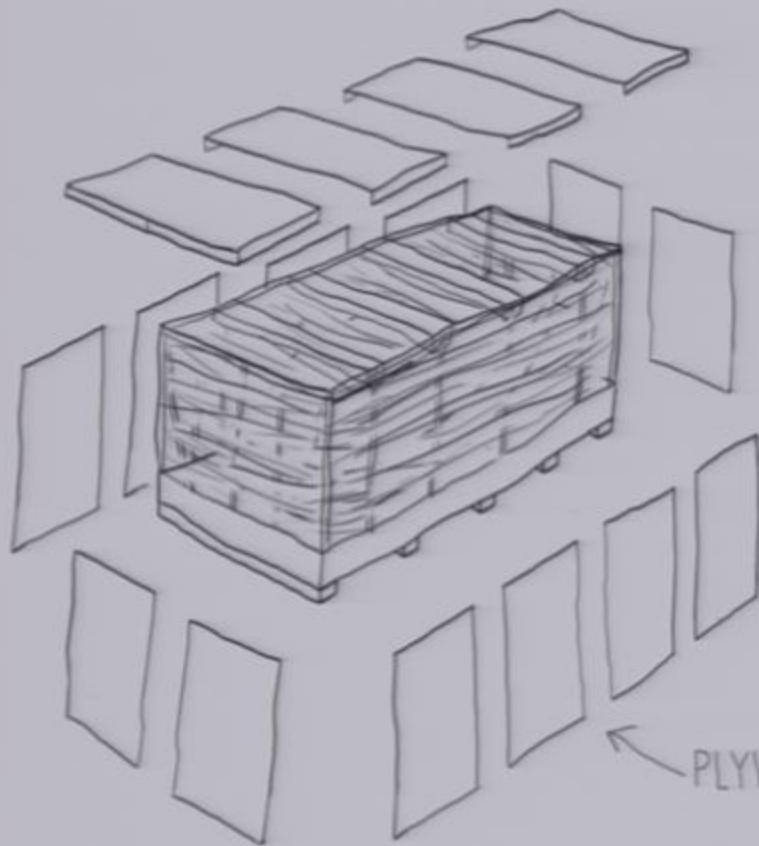

PLYWOOD SKINS



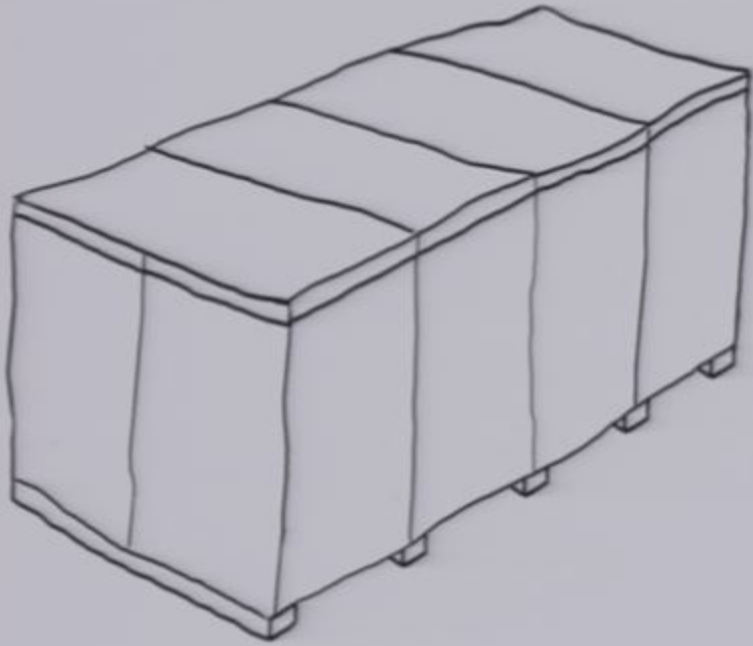

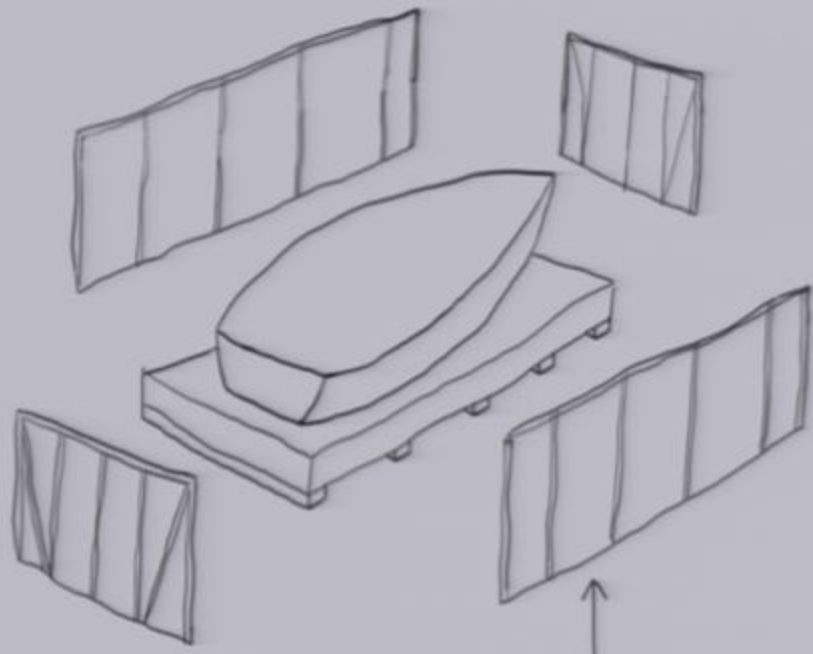

TIMBER  
FRAMEWORK



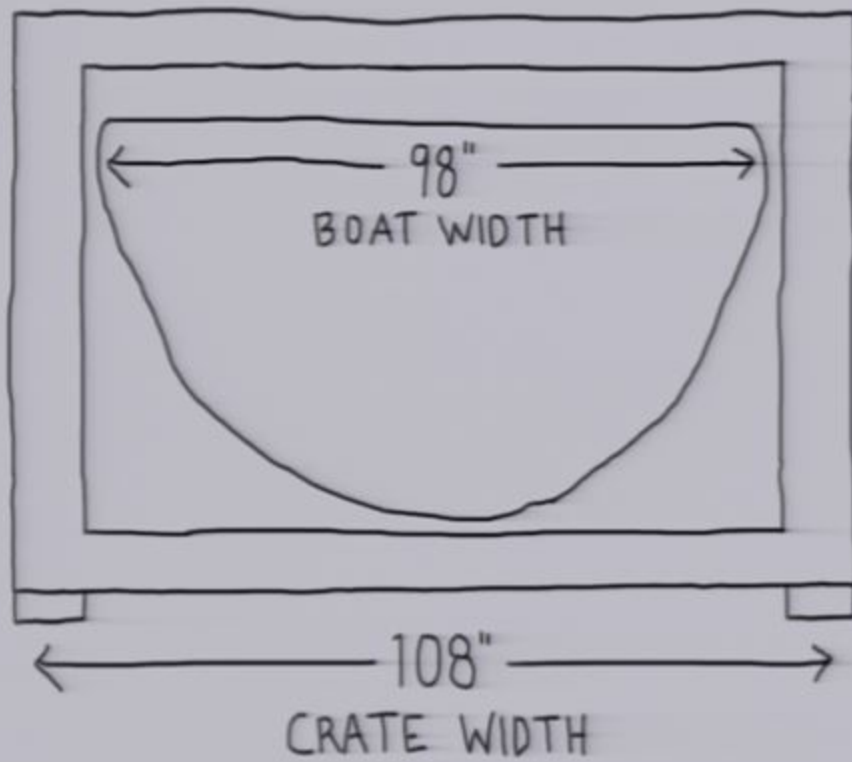

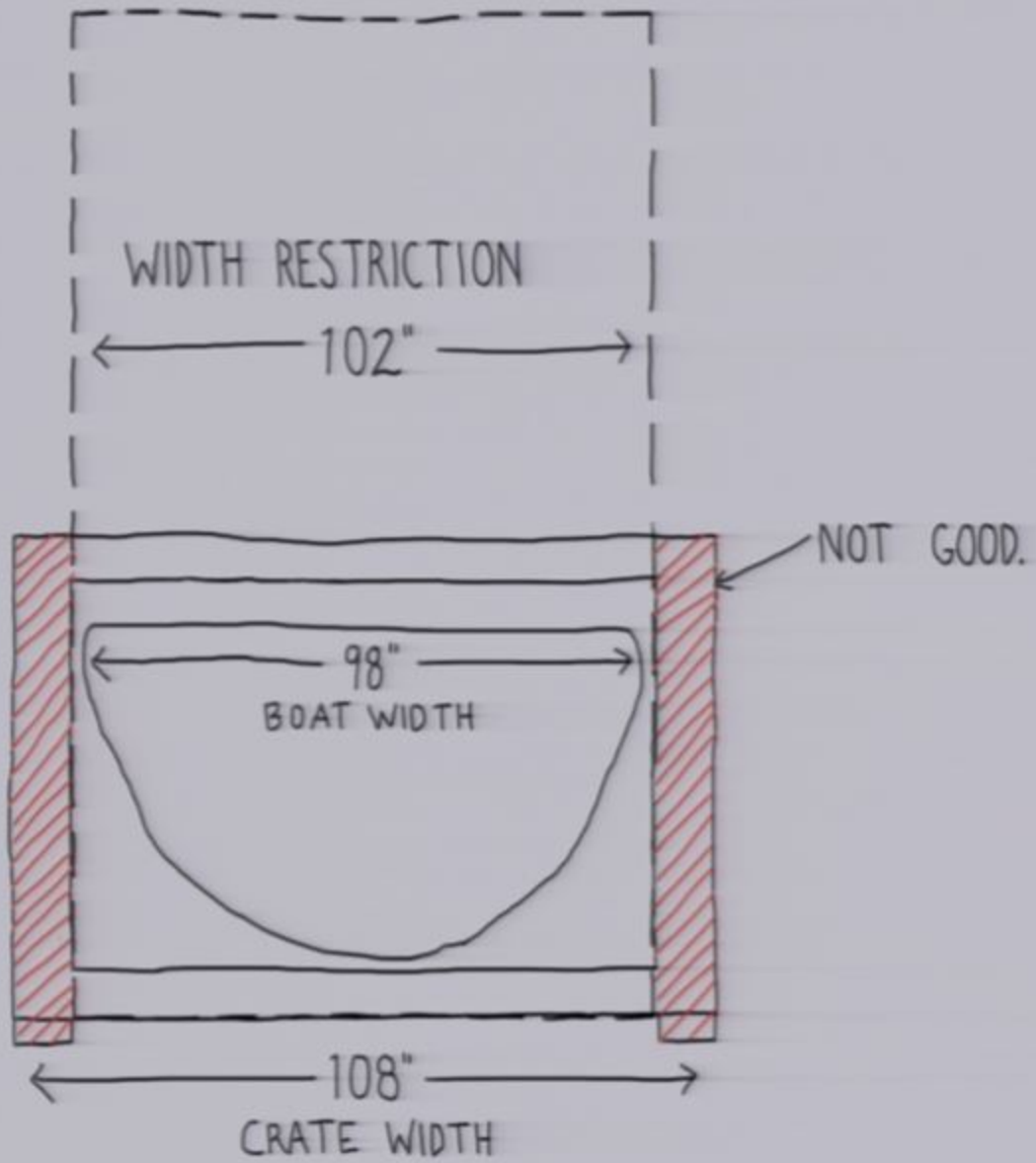



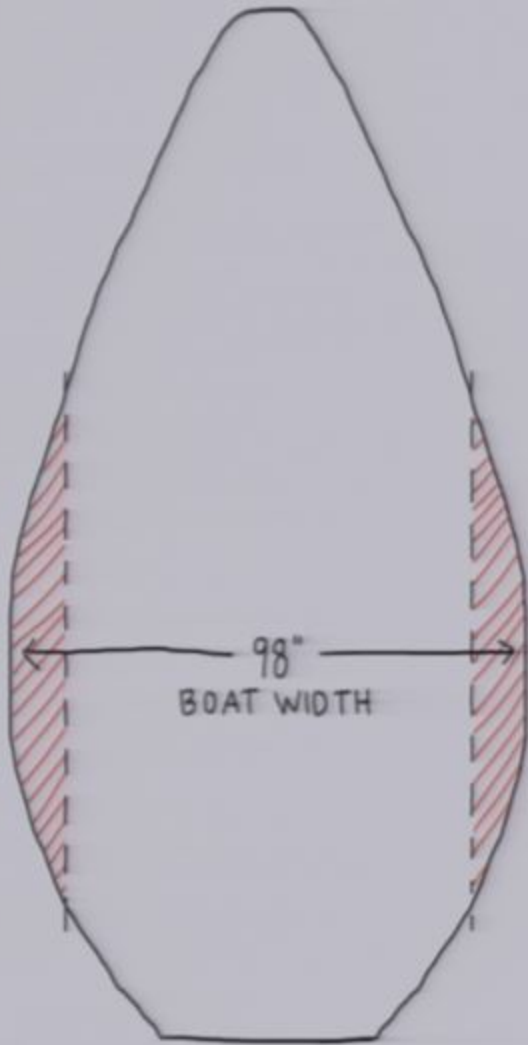
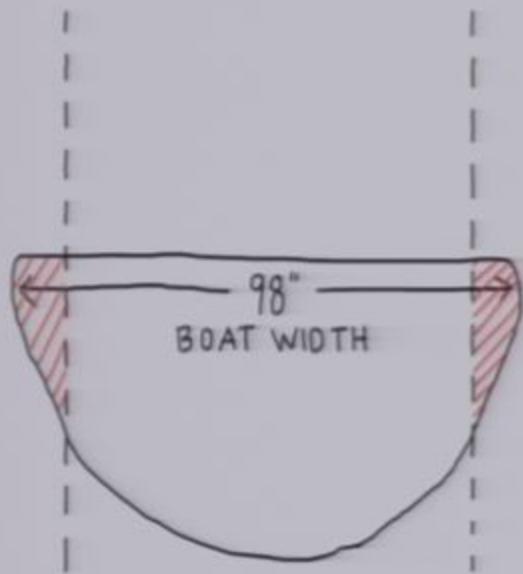

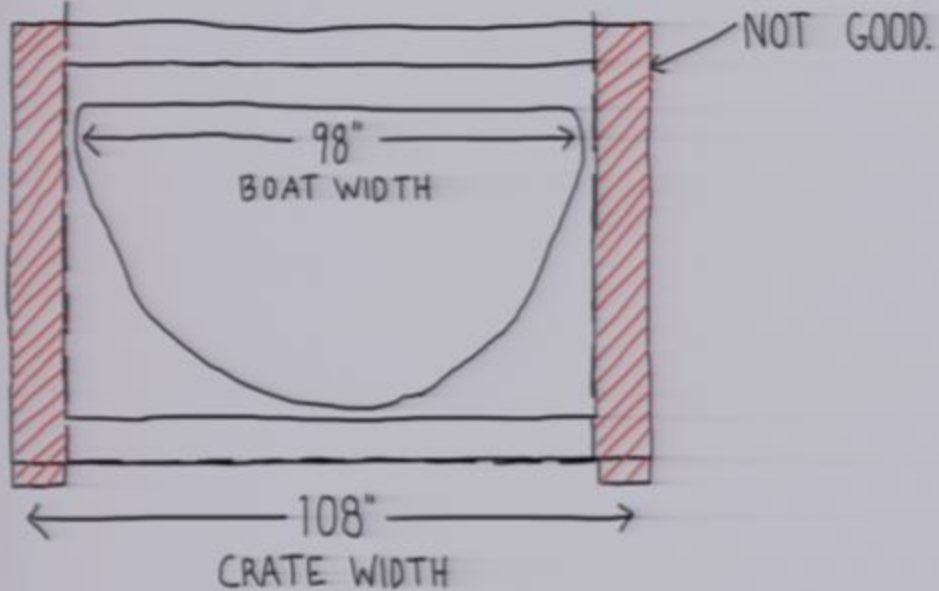
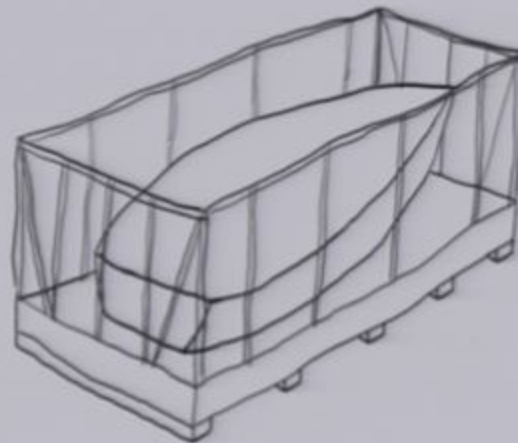
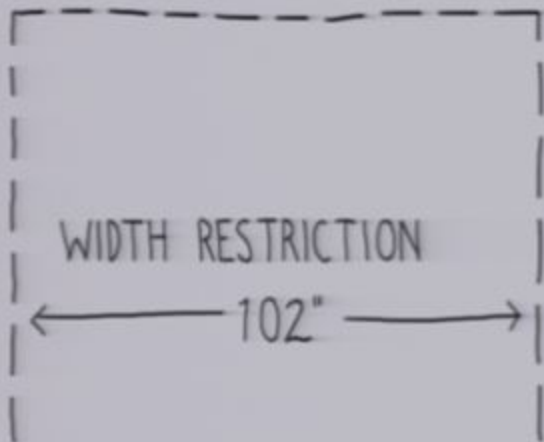

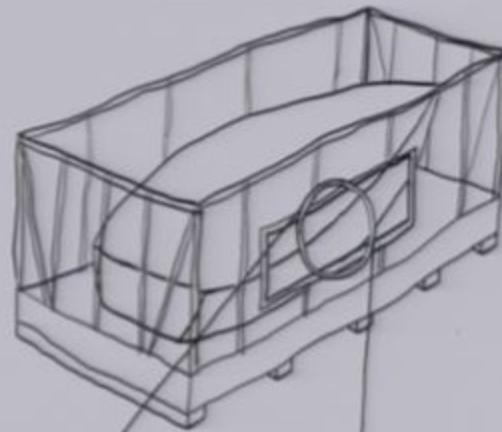
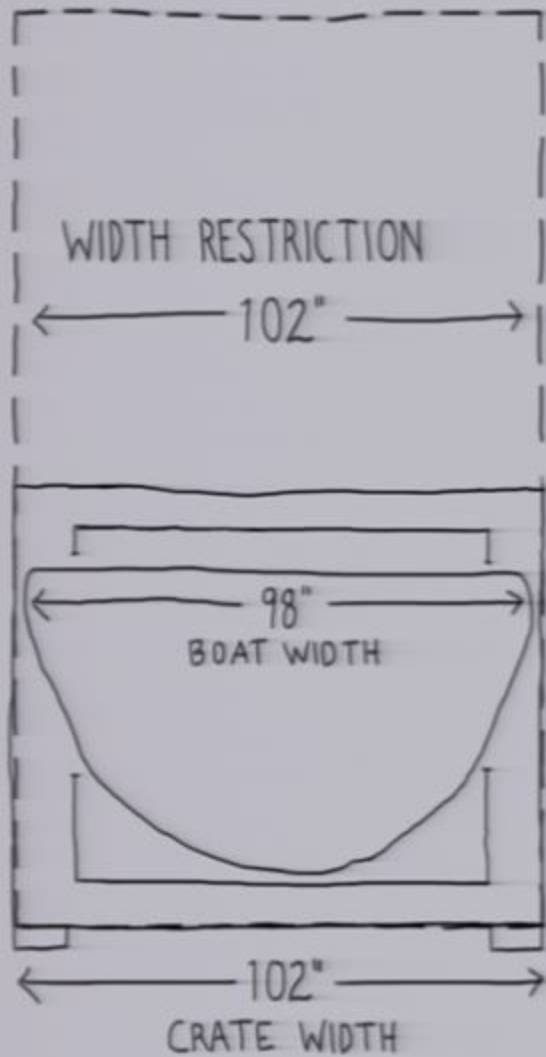

SIDE VIEW

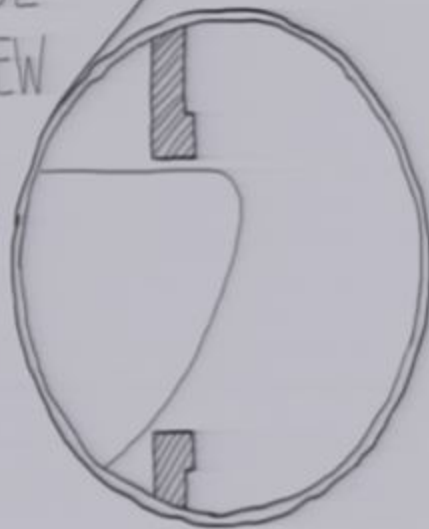

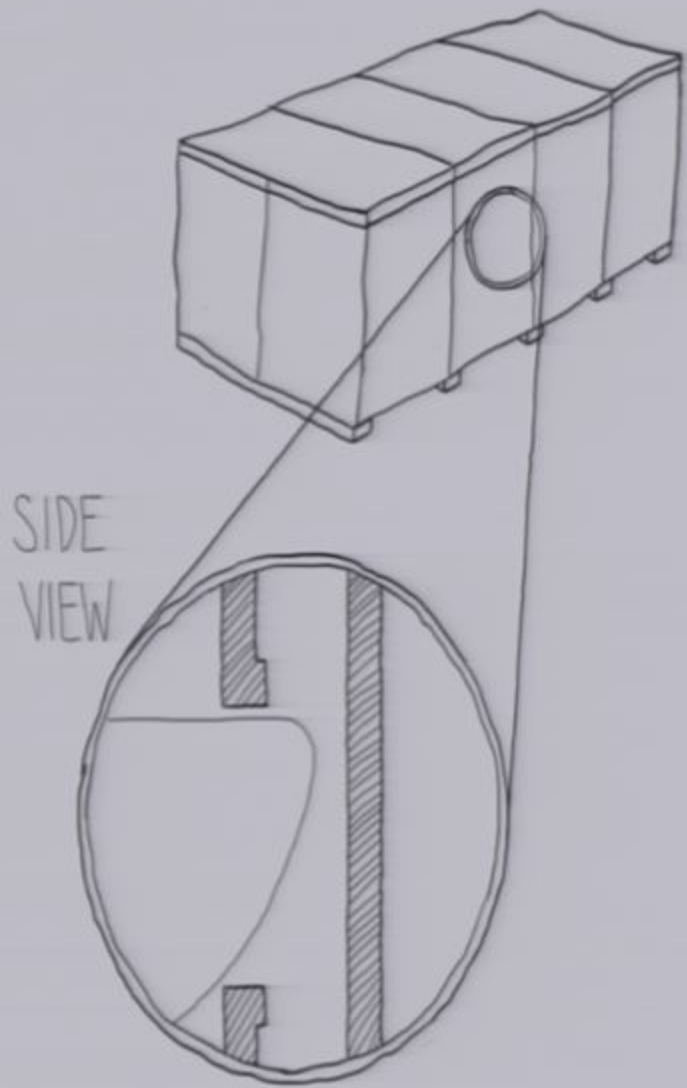
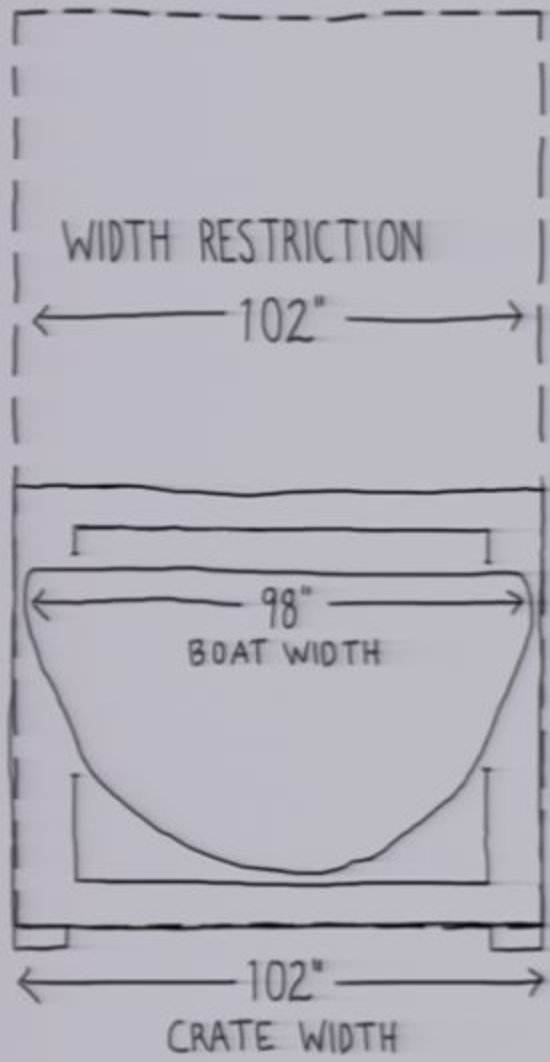

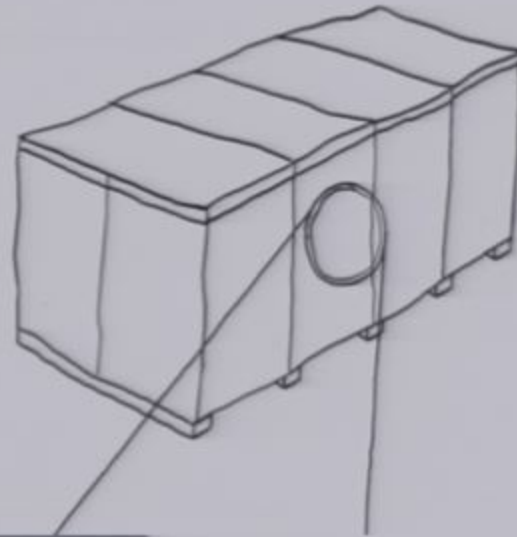
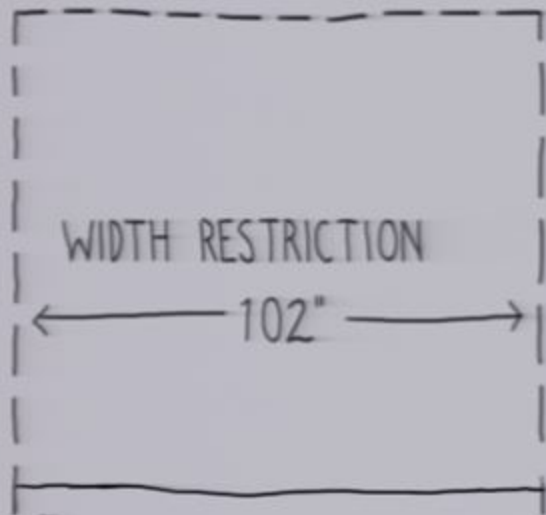

SIDE

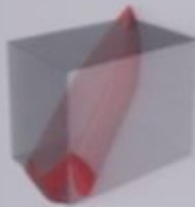

Option B - Old Freight Elevator, 10'6" x 18'9" x 12'6"

Will not fit same as option A

Not an option

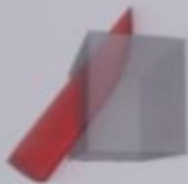

Option C - Rig through elevator shaft

May fit but would risk damage to boat

Budco shaft rigging cost  $\$30-\$30,000 \times 2 =$   $\$60-\$60,000$

MCMA/Budco installation rigging cost  $\$10,000/\$36,000$

Arrow installation  $\$5,250 \times 2 =$   $\$10,500$

Total:  $\$80,500 - \$10,500 / \$96,500 - \$46,500$



Boxart sled fabricated	\$20,000
Budco installation rigging cost	\$10,000/\$36,000
Arrow installation $\$5,250 \times 2 =$	\$10,500
Total:	\$40,500/\$66,500

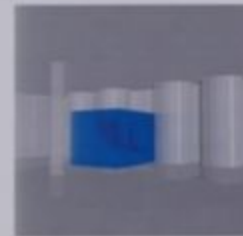

Option F - Bring through revolving doors and rig to 2<sup>nd</sup> FL atrium

Shuldiner revolving door removal  $\$72,556 \times 2 =$   $\$145,112$

Shuldiner 2<sup>nd</sup> FL glass removal  $\$12,000 \times 2 =$   $\$24,000$

Nalco Sliding door removal  $\$1,720 \times 2 =$   $\$3,440$

Budco Rigging  $\$65,000 \times 2 =$   $\$130,000$

MCMA/Budco installation rigging cost  $\$10,000/\$36,000$

Arrow installation  $\$5,250 \times 2 =$   $\$10,500$

Total:  $\$325,052/\$351,052$

# MoMA Installation Options AKA how do we get this giant crate into the building ?

Chi - Guo Qiang : Borrowing your Enemy's Arrows

MoMA Installation options - 12/15/14

Crate: 78 1/8" x 294 1/2" x 102"

Art: 59 1/16" x 283 7/16" x 90 9/16"

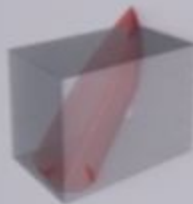

Option A - New Freight Elevator, 10'10" x 17'3" x 12"

Proposed to have at angle with two gentries but will not fit.

Not an option

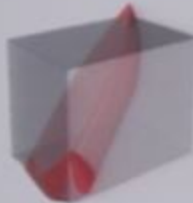

Option B - Old Freight Elevator, 10'6" x 18'6" x 12'6"

Will not fit same as option A.

Not an option



Option C - Rig through elevator shaft

May fit but would risk damage to boat.

Budco shaft rigging cost \$30-\$50,000 x 2 = \$60-\$100,000

MoMA/Budco installation rigging cost \$10,000/\$36,000

Arrow installation \$5,250 x 2 = \$10,500

Total: \$80,500 - \$100,500 / \$106,500 - \$146,500



Option D - Bring through rollup door on 2<sup>nd</sup> FL

Involves coordination with Hines project.

Budco Crane cost \$44,000 x 2 = \$88,000

MoMA/Budco installation rigging cost \$10,000/\$36,000

Arrow installation \$5,250 x 2 = \$10,500

Total: \$108,500/\$134,500

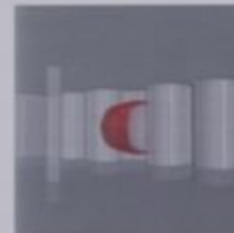

Option E - Turn boat to fit through double doors 96" x 77"

Boxcar sled fabricated \$20,000

Budco installation rigging cost \$10,000/\$36,000

Arrow installation \$5,250 x 2 = \$10,500

Total: \$40,500/\$66,500

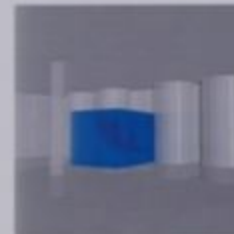

Option F - Bring through revolving doors and rig to 2<sup>nd</sup> FL atrium.

Shuldiner revolving door removal \$72,556 x 2 = \$145,112

Shuldiner 2<sup>nd</sup> FL glass removal \$12,000 x 2 = \$24,000

Nalco Sliding door removal \$1,720 x 2 = \$3,440

Budco Rigging \$45,000 x 2 = \$90,000

MoMA/Budco installation rigging cost \$10,000/\$36,000

Arrow installation \$5,250 x 2 = \$10,500

Total: \$325,052/\$351,052





## PUBLIC NOTICE

PLEASE BE ADVISED THAT ON 31 JANUARY & 1 FEBRUARY 2015, FROM 8AM TO 8PM, WEST 54<sup>TH</sup> STREET BET 5<sup>TH</sup> AVE & 6<sup>TH</sup> AVE WILL BE CLOSED TO VEHICULAR TRAFFIC DUE TO A CRANE OPERATION AT 11 WEST 53<sup>RD</sup> STREET. WE APOLOGIZE FOR ANY INCONVENIENCE THIS MAY CAUSE.





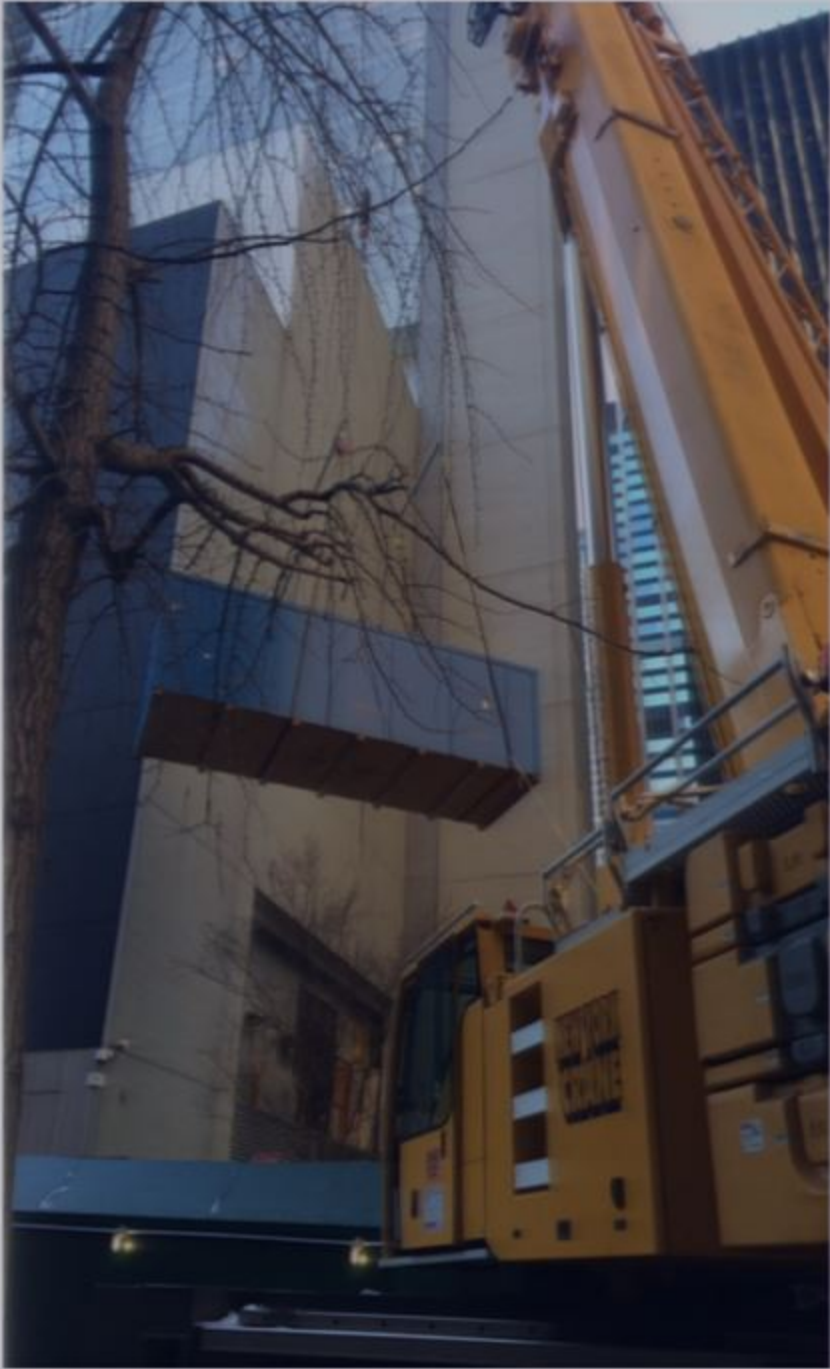







### Checklist with All Images

Cai Guo-Qiang (Chinese, born 1957)  
Borrowing Your Enemy's Arrows, 1998  
Woodboat, canvas sail, arrows, metal, rope, Chinese flag, and electric fan  
Boat approximately 60" x 23 7/8" x 7 8/8" (152.4 x 720 x 230 cm), each arrow  
approximately 24" (62 cm)  
Gift of Patricia Phelps de Cisneros in honor of Glenn D. Lowy  
©1998





































## Cai Guo-Qiang

### *Borrowing Your Enemy's Arrows*, 1998

Wood boat, canvas sail, arrows, metal, rope, Chinese flag, and electric fan

Boat approximately 60" x 23' 7" x 7' 6" (152.4 x 720 x 230 cm), each arrow approximately 24" (62 cm)

Gift of Patricia Phelps de Cisneros in honor of Glenn D. Lowry





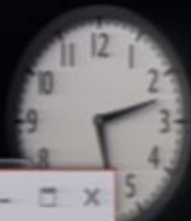
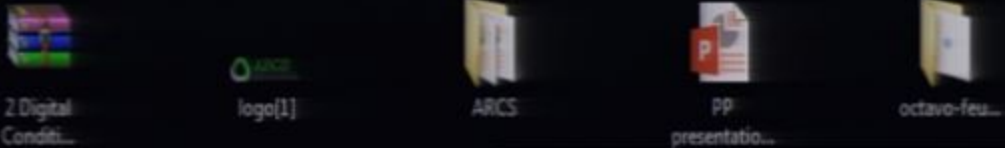

8 Acquiring Contemporary Art - PowerPoint

FILE HOME INSERT DESIGN TRANSITIONS ANIMATIONS SLIDE SHOW REVIEW VIEW

Clipboard Slides Font Paragraph Drawing Editing

1  
2  
3  
4  
5  
6  
7  
8  
9  
10

# Contemporary Art vs. The Museum

Why is acquiring and caring for contemporary art so challenging?

Presented by Sydney Briggs, Ellen Cant,  
Sandi Panofsky, with Carol Harford

Click to add notes

SLIDE 1 OF 123

NOTES COMMENTS

54%

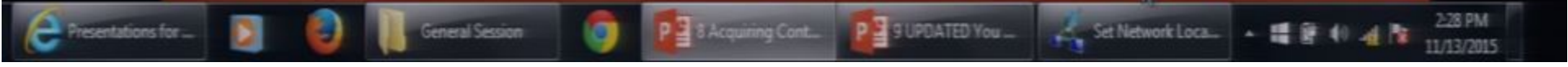



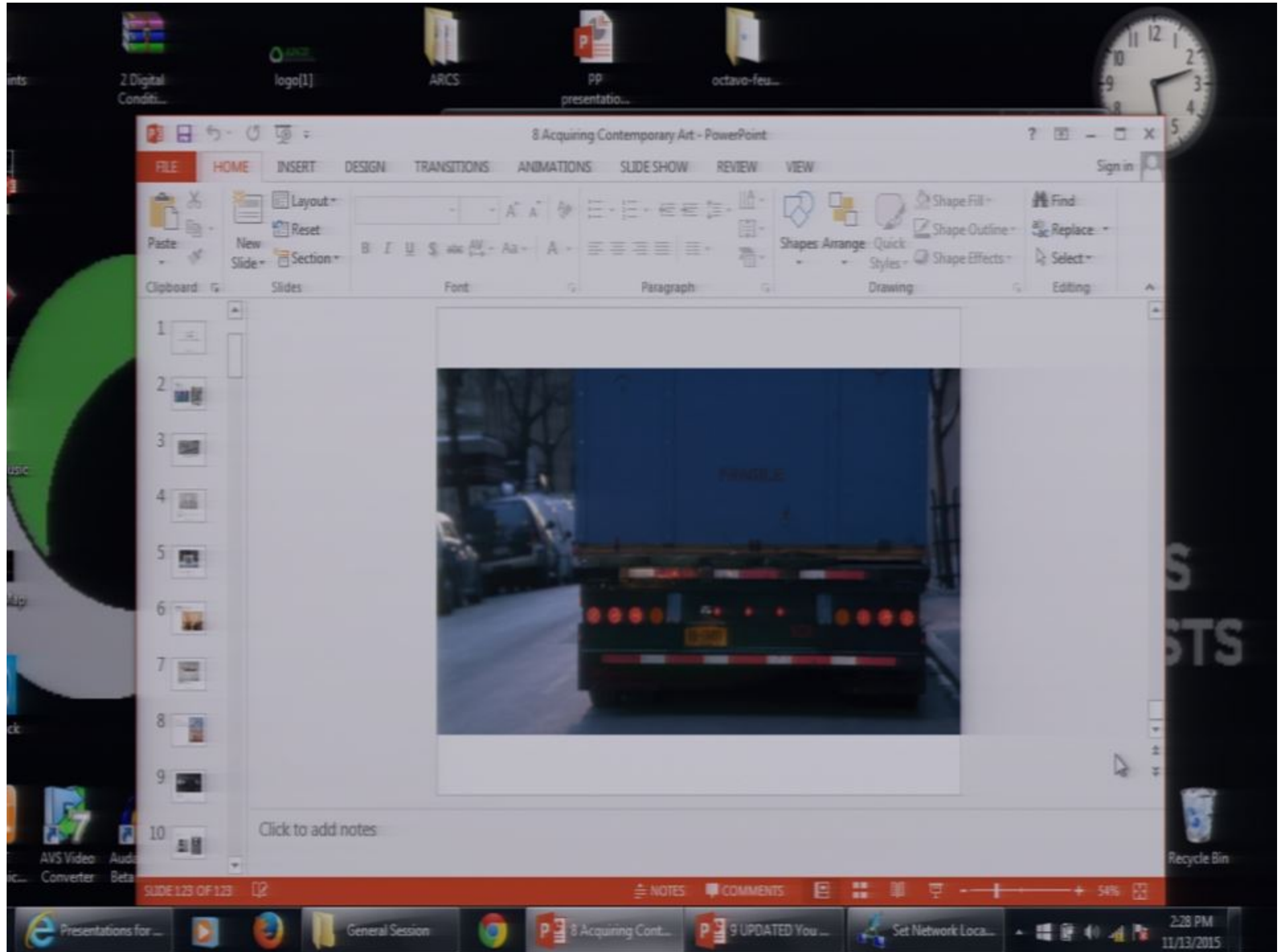

2 Digital Condi... logo[1] ARCS PP presentatio... octavo-feu...

8 Acquiring Contemporary Art - PowerPoint

FILE HOME INSERT DESIGN TRANSITIONS ANIMATIONS SLIDE SHOW REVIEW VIEW

Paste Layout Reset New Slide Section Font Paragraph Drawing Editing

114 115 116 117 118 119 120 121 122 123



Play video

SLIDE 123 OF 123

NOTES COMMENTS

Presentations for ... General Session 8 Acquiring Cont... 9 UPDATED You ... Set Network Loca...

2:28 PM 11/13/2015

2 Digital Condi... logo[1] ARCS PP presentatio... octavo-feu...

8 Acquiring Contemporary Art - PowerPoint

FILE HOME INSERT DESIGN TRANSITIONS ANIMATIONS SLIDE SHOW REVIEW VIEW Sign in

Paste New Slide Layout Reset Section Font Paragraph Drawing Editing

114 115 116 117 118 119 120 121 122 123

Play video [No Title]

SLIDE 123 OF 123

NOTES COMMENTS 54%

Presentations for... General Session 8 Acquiring Cont... 9 UPDATED You... Set Network Loca... 2:28 PM 11/13/2015

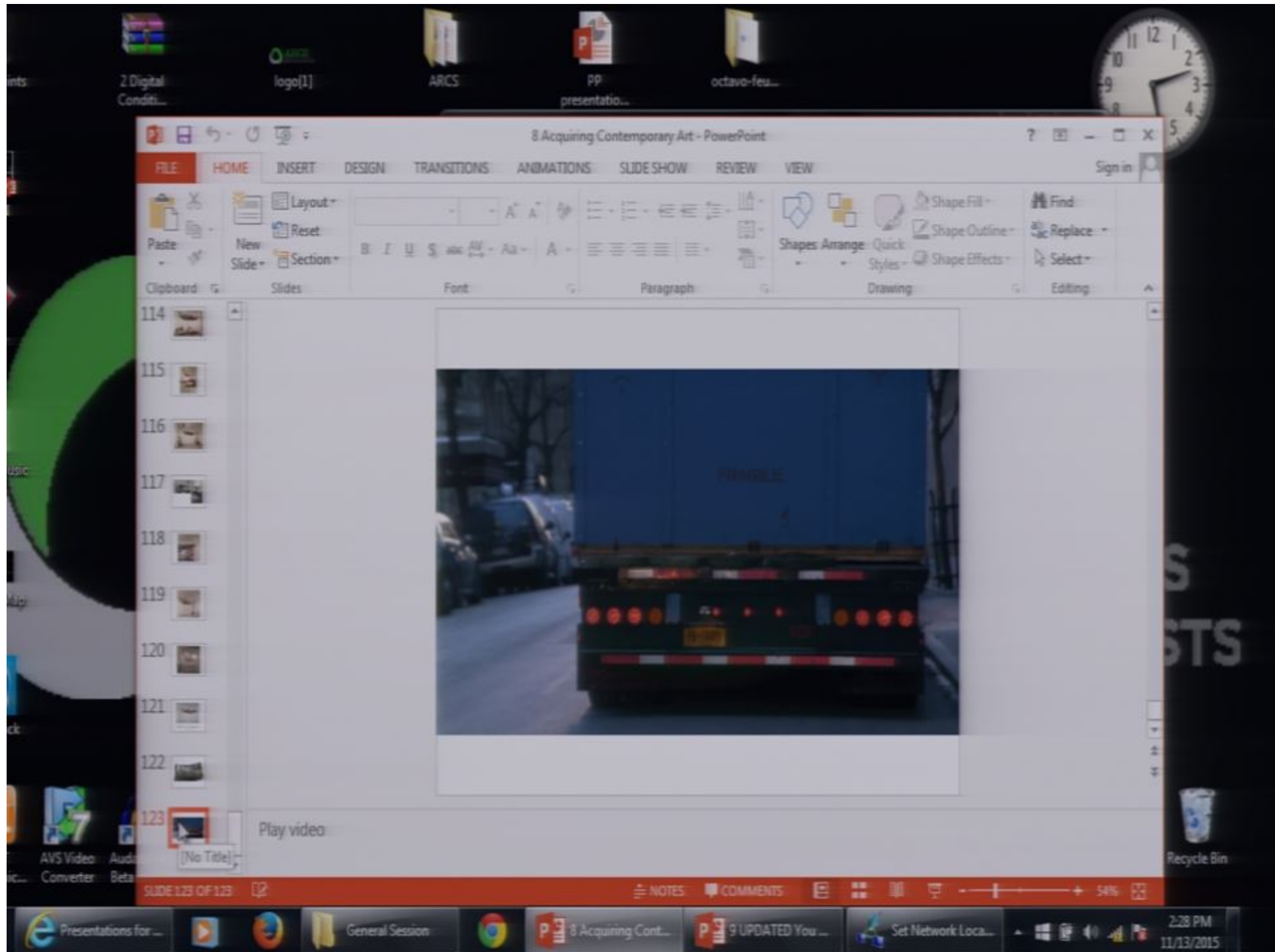
A screenshot of a Windows desktop environment. In the foreground, a Microsoft PowerPoint window is open, displaying slide 123 of 123. The slide contains a video player with a play button and the text "[No Title]". The video frame shows the rear of a dark-colored truck with a blue trailer, parked on a street. The PowerPoint ribbon is visible at the top, showing the "HOME" tab with various editing options like Paste, Layout, Font, Paragraph, Drawing, and Editing. The Windows taskbar at the bottom shows several open applications, including "Presentations for...", "General Session", "8 Acquiring Cont...", and "9 UPDATED You...". The system tray on the right shows the time as 2:28 PM on 11/13/2015. In the background, a desktop clock is visible in the top right corner, and various icons are scattered on the desktop.

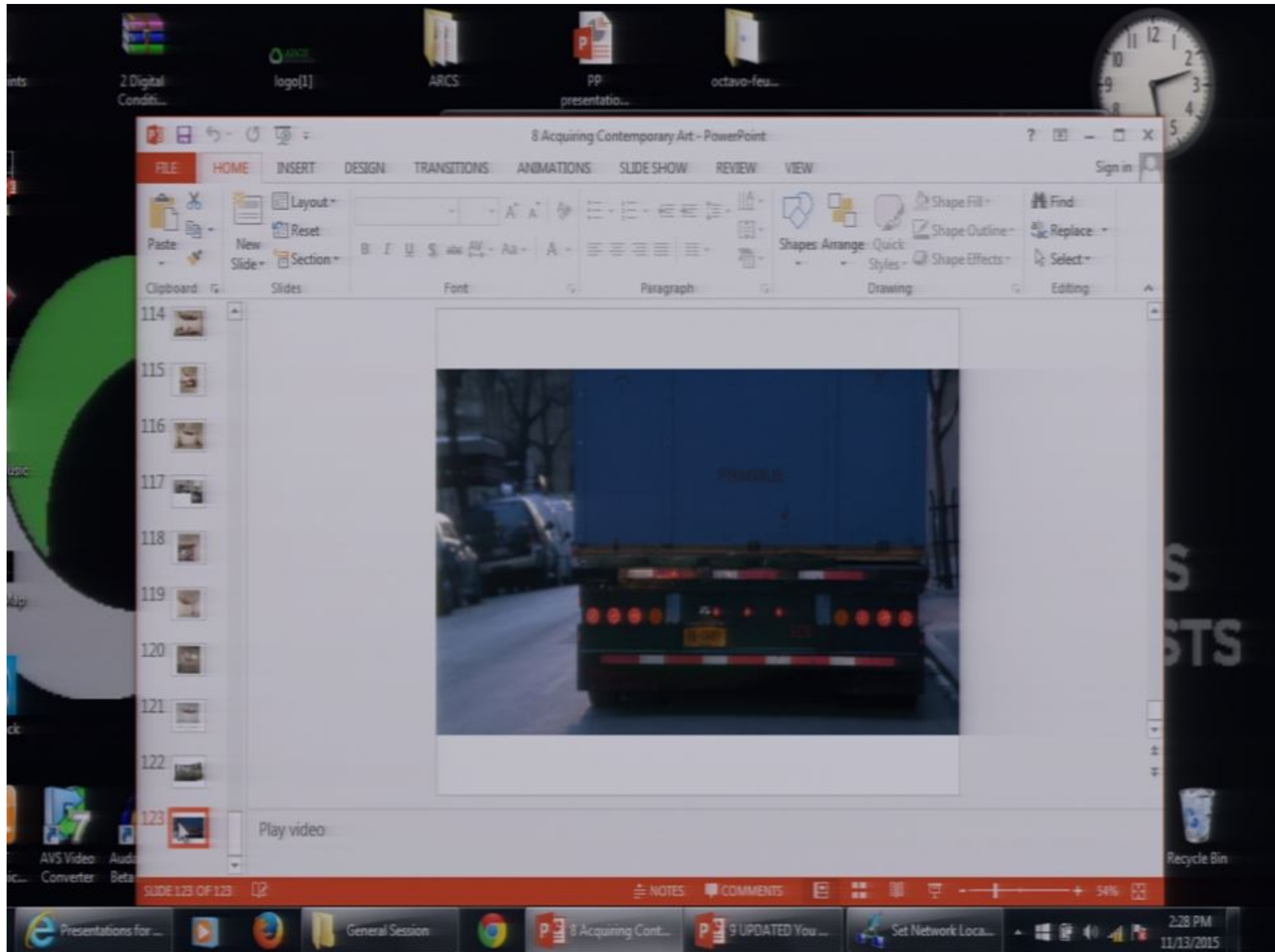



















































We dug the boat out of the mire



at the seashore in my hometown.



A worker wearing an orange jacket, a black cap, and white gloves is using a power drill on a blue door. The worker is standing on a metal platform or scaffolding. The door has a green label on the left side and the letters "A1" written on it. The background is a plain, light-colored wall.

It was actually covered in sludge.

A man wearing an orange jacket, a black cap, and gloves is using a spray gun to apply a substance to a blue door. He is standing on a metal platform or scaffolding. The door has a green label and the letters 'AL' are visible on it. The background is a plain, light-colored wall.

It was actually covered in sludge.

A person wearing a red jacket, a black cap, and white gloves is standing in a laboratory or industrial setting. They are positioned behind a metal frame structure. The background features a plain white wall and a large blue door. A green sign is visible on the door, and the letters "AL" are faintly visible on the lower right portion of the door. The person appears to be handling a small object or component within the frame.

It was actually covered in sludge.

A person wearing a bright red protective suit, a black cap, and white gloves is working with a metal frame. The person is looking down at something in their hands. The background is a plain white wall with a blue door to the right. A green sign is visible on the door. The scene is dimly lit, suggesting an indoor laboratory or industrial setting.

It was actually covered in sludge.





A person wearing a dark jacket and a beanie stands in profile, looking towards the left. They are positioned next to a blue metal structure that recedes into the distance. The background is a clear, light-colored sky. The overall scene is dimly lit, suggesting an overcast day or early morning/late evening.

So we waited till the tide had taken  
some of the sludge away



So we waited till the tide had taken  
some of the sludge away



So we waited till the tide had taken  
some of the sludge away



So we waited till the tide had taken  
some of the sludge away



to dig the boat out.



to dig the boat out.



Then we cleaned and disassembled it.





Then we cleaned and disassembled it,



Then we cleaned and disassembled it,



Then we cleaned and disassembled it,



Then we cleaned and disassembled it,



and eventually brought it to New York.



and eventually brought it to New York.



and eventually brought it to New York.















I wanted to expose the skeleton.



I wanted to expose the skeleton.





the frame of the boat, which  
looked more like an artwork.





the frame of the boat, which  
looked more like an artwork.



the frame of the boat, which  
looked more like an artwork.



the frame of the boat, which  
looked more like an artwork.



the frame of the boat, which  
looked more like an artwork.







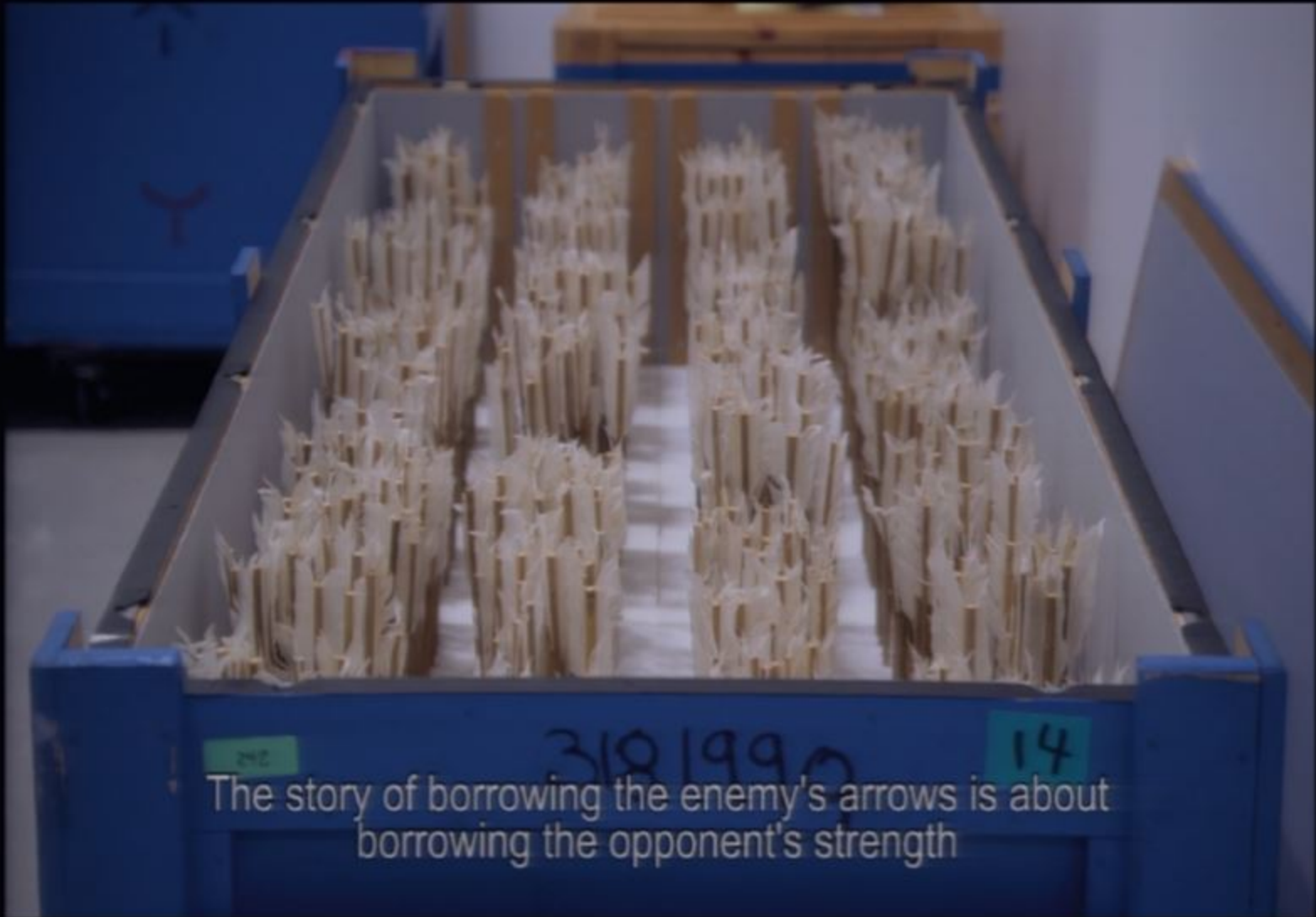

The story of borrowing the enemy's arrows is about borrowing the opponent's strength





The story of borrowing the enemy's arrows is about  
borrowing the opponent's strength





to make oneself strong in a short time.



to make oneself strong in a short time.







There was a very resourceful general  
called Zhuge Liang.



There was a very resourceful general  
called Zhuge Liang.





There was a very resourceful general  
called Zhuge Liang.



There was a very resourceful general  
called Zhuge Liang.





He filled boats with straw soldiers and sailed toward the enemy's camp.

United Rentals 5488 3216



He filled boats with straw soldiers and sailed toward the enemy's camp.

United Rentals 5488 3219



He filled boats with straw soldiers and sailed toward the enemy's camp.

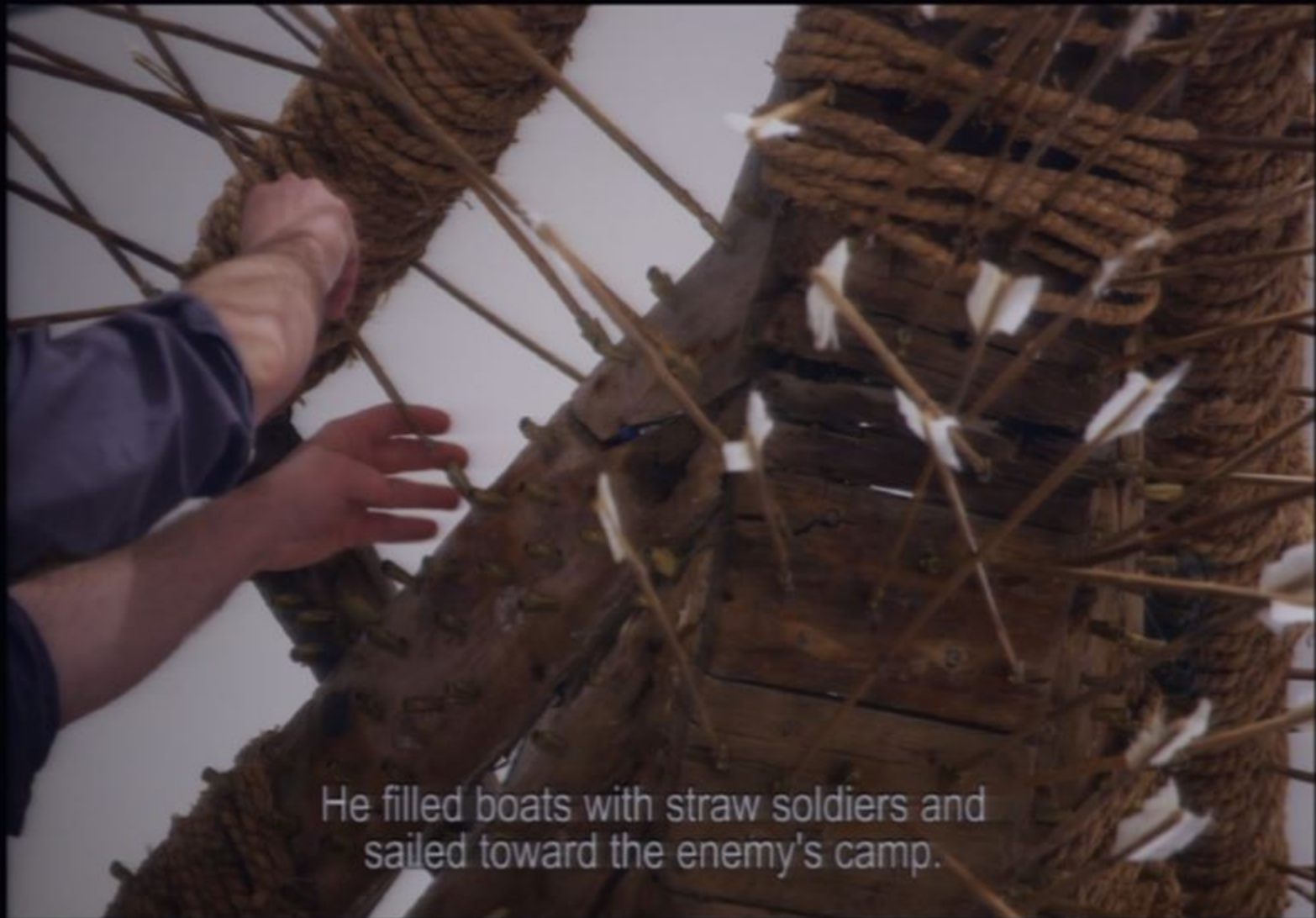

He filled boats with straw soldiers and sailed toward the enemy's camp.

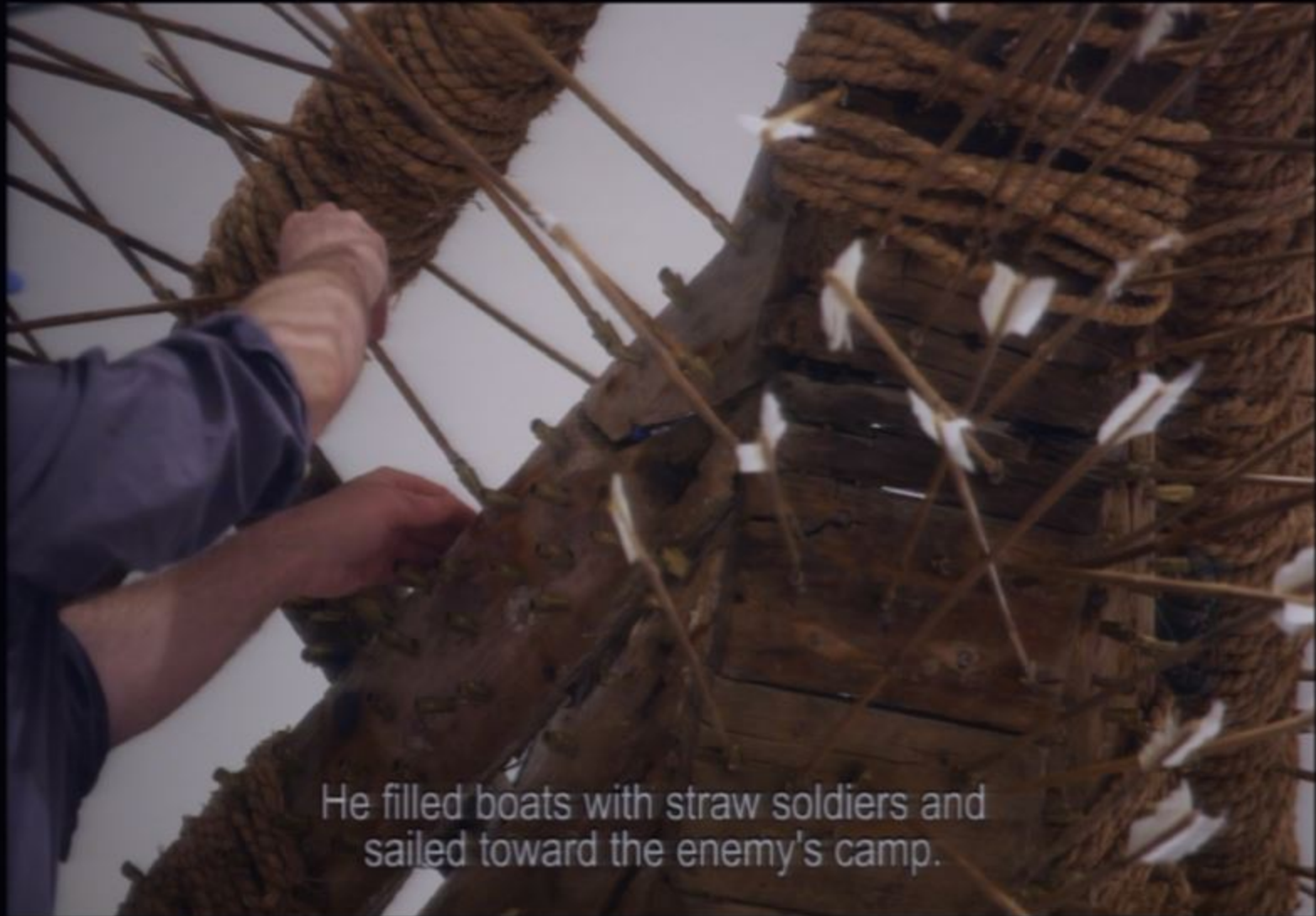

He filled boats with straw soldiers and sailed toward the enemy's camp.





He filled boats with straw soldiers and sailed toward the enemy's camp.



Mistaking the boats with straw soldiers for a surprise attack,



Mistaking the boats with straw  
soldiers for a surprise attack,



Mistaking the boats with straw soldiers for a surprise attack.





the enemy showered the decoys with volleys of arrows.



the enemy showered the decoys with volleys of arrows.



the enemy showered the decoys with volleys of arrows.

































The boat is a very familiar object to me.



The boat is a very familiar object to me.



The boat is a very familiar object to me.





It is one of the earliest vehicles that helped humans understand their relationship with gravity.



However, when the body of the boat is full of arrows like feathers.



However, when the body of the boat is full of arrows like feathers.



However, when the body of the boat is full of  
arrows like feathers.



However, when the body of the boat is full of  
arrows like feathers.



However, when the body of the boat is full of arrows like feathers,



However, when the body of the boat is full of  
arrows like feathers.



it suddenly transforms into a bird and  
seems to be able to fly.



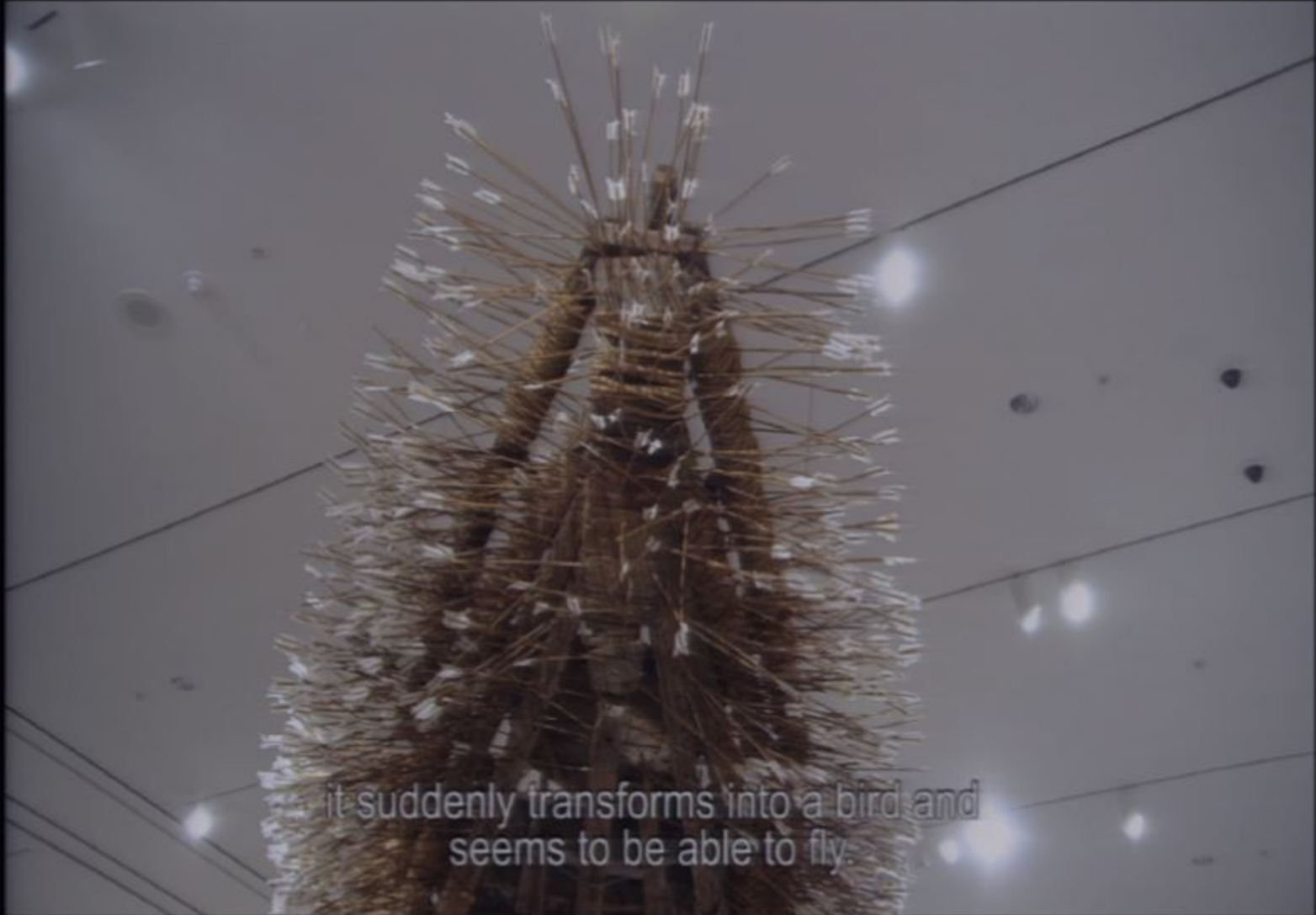

it suddenly transforms into a bird and  
seems to be able to fly.





FRAGILE

BA-18491

SDS

